

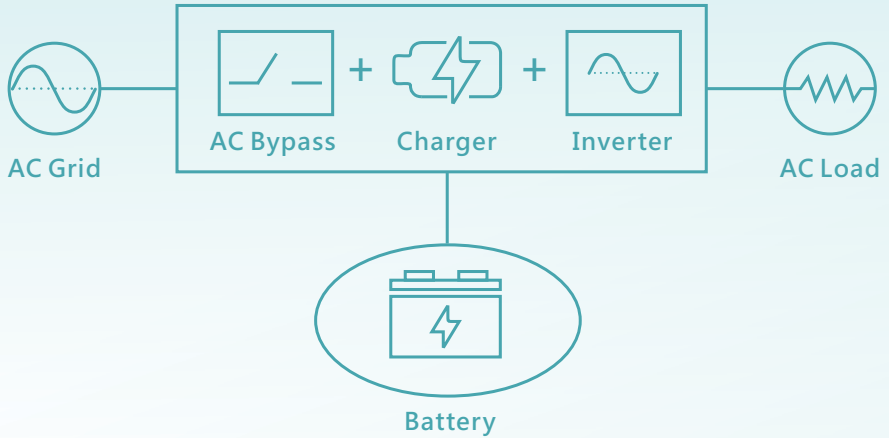

# NTN-5K Series

## Installation manual



***True Sine Wave Inverter***

• High Reliable Inverter •

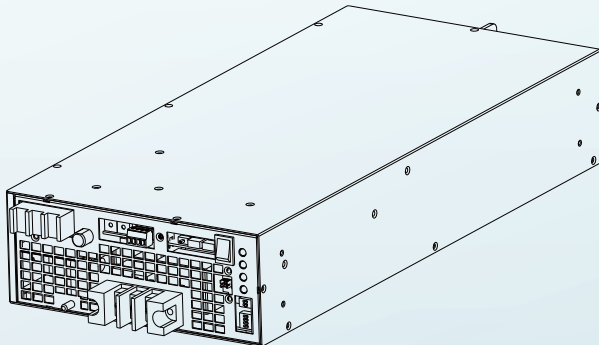

NTN-5K is a 5KW highly reliable off-grid true sine wave DC-AC power inverter with built-in AC charger and UPS function(AC by-pass). Its key features include: digital design with MCU control, streamlined control circuitry that quickly responds to environmental changes and improves reliability, high quality fan with low acoustic noise, 10KW peak power, adjustable AC output voltage and frequency, -30~+70°C wide. Operating temperature range, complete protection features, and etc. Combined with batteries, the NTN-5K is suitable for use in residential, commercial, marine, automobile, mine, construction site, and remote areas with no access to utility power, and the output can be used to power fans, TV, radio, phone charger, PC/laptop, lighting, induction stove, air conditioner, electromechanical tool, communication equipment, power distribution cabinet, outdoor camping equipment, marine AC power, factory equipment, and etc.

# Contents

<b>1.Safety Guidelines</b>	1	5.4 Single-phase 3-wire Output (124/148 only)	27
<b>2.Introduction</b>	2	5.5 Remote ON-OFF Control	31
2.1 Model Encoding	2	5.6 Explanation of Operating Logic	32
2.2 Features	2	5.7 AC Charger	37
2.3 Specification	3	5.8 CMU2E, the GUI Controller For the NTN-5K	42
2.4 Derating Curve	7	5.9 Factory Resetting	43
2.5 Mechanical Specification	8	<b>6.Communication Protocol</b>	44
<b>3.Installation &amp; Wiring</b>	11	6.1 Modbus Communication Interface	44
3.1 Precautions	11	6.2 CAN Bus Communication Interface	68
3.2 System Block Diagram	11	6.3 Value Range and Tolerance	88
3.3 Installation Procedures	12	<b>7.Protections and Troubleshooting</b>	91
3.4 Battery Wiring Selection	12	7.1 Protections	91
3.5 Battery Selection	12	7.2 Troubleshooting	92
<b>4.User Interface</b>	13	<b>8.Warranty</b>	93
4.1 AC Panel	13	<b>9.Environmental declaration information</b>	94
4.2 DC Panel	14		
4.3 LED Indicators	14		
4.4 Pin Assignment of CRL	16		
4.5 Pin Assignment of COMM	17		
4.6 Pin Assignment of PAR1,PAR2	18		
4.7 Pin Assignment of Remote Switch	19		
4.8 Communication Address /ID Assignment	20		
<b>5.Explanation of Operation</b>	21		
5.1 Procedure of Setting Output voltage, Frequency and Saving Mode	21		
5.2 Parallel Synchronized Operation	22		
5.3 Three-phase 4-wire Output	23		

# 1.Safety Guidelines

- Risk of electrical shock and energy hazard, all failures should be examined by the qualified technician. Please do not remove the case of the inverter by yourself.
- Please refrain from situating the inverter in damp environments or in close proximity to water sources.
- Please do not install the inverter in places with high ambient temperature or under direct sunlight.
- Please only connect batteries with the same brand and model number in one battery bank. Using batteries from different manufacturers or different capacity is strictly prohibited!
- Never allow a spark or flame in the vicinity of the batteries because they may ignite explosive gases during normal operation.
- Make sure the air flow from the fan is not obstructed at both sides (front and back) of the inverter. (Please allow at least 15cm of space).
- Please do not stack any object on the inverter.
- Please do not turn on the inverter before start the engine if the inverter is connected to vehicle's battery directly.
- Branch rated over current protection for the AC output circuit is to be provided at the time of installation.

# 2.Introduction

## 2.1 Model Encoding

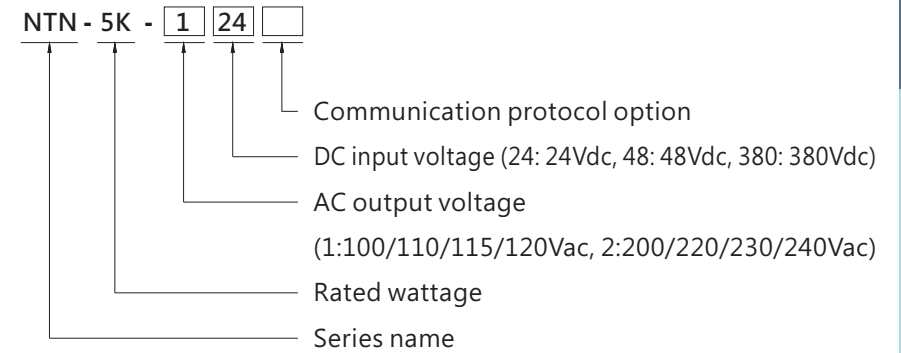

Type	Communication Protocol	Note
Blank	Modbus protocol	In Stock
CAN	CAN Bus protocol	In Stock

## 2.2 Features

- Combining AC/DC charger, DC/AC Inverter, AC by-pass & support external MPPT solar charger
- AC utility charger up to 4520W
- UPS function (AC by-pass) without interruption, transfer time <10ms
- True sine wave output (THD <3%)
- High surge power up to 10KW
- Parallel synohronized operation up to 30KW (5+1 unit)
- Temperature controlled cooling fan
- AC output voltage and frequency selectable by DIP S.W
- Protections:  
 Input: Reverse polarity / DC low alarm / DC low shutdown / Over voltage  
 Output : Short circuit / Overload / Over temp.
- Battery over discharge protection (low voltage disconnect)
- -30°C~ +70°C wide operating temperature
- Suitable for lead-acid or li-ion batteries
- Support MODBus-RTU(RS-485) or CAN Bus protocol communication
- Graphical user interface controller CMU2E/CMUE-R for status monitoring and control
- Conformal coating
- 5 years warranty

## 2.3 Specification

MODEL		NTN-5K-224 <input type="checkbox"/>	NTN-5K-248 <input type="checkbox"/>	NTN-5K-2380 <input type="checkbox"/>		
		<input type="checkbox"/> =Blank, CAN				
AC OUTPUT	RATED POWER(Continuous)	5000W				
	OVER RATED POWER(3 Min.)	5750W				
	PEAK POWER(10 Sec.)	7000W	7500W			
	SURGE POWER(30 Cycles)	8000W	10000W			
	AC VOLTAGE	Default setting set at 230VAC 200 / 220 / 230 / 240Vac selectable by DIP S.W				
	FREQUENCY	Default setting set at 50Hz±0.1Hz 50/60Hz selectable by DIP S.W				
	WAVEFORM <small>Note.1</small>	True sine wave (THDv<3%)				
AC REGULATION	±3.0% at rated input voltage					
DC INPUT	DC VOLTAGE	24Vdc	48Vdc	380Vdc		
	VOLTAGE RANGE (Typ.)	19 ~ 33Vdc	38 ~ 66Vdc	280 ~ 430Vdc		
	DC CURRENT (Typ.)	240A	120A	16A		
	NO LOAD	NON-SAVING MODE	2.5A	1.4A	0.2A	
	DISSIPATION (Typ.)	SAVING MODE	Default disable, auto detect AC output load ≤10W will be changed to saving mode			
			<25W			
	OFF MODE CURRENT DRAW	≤2mA				
	EFFICIENCY (Typ.) <small>Note.1</small>	91%	93%	94.5%		
BATTERY TYPES	Lead Acid or li-ion					
PROTECTION	DC INPUT	LOW	ALARM	22±0.5Vdc	44±1Vdc	300±5Vdc
			SHUTDOWN	19±0.5Vdc	38±1Vdc	280±5Vdc
			RESTART	25±0.5Vdc	50±1Vdc	335±5Vdc
		HIGH	ALARM	31±0.5Vdc	62±1Vdc	420±5Vdc
			SHUTDOWN	33±0.5Vdc	66±1Vdc	430±5Vdc
			RESTART	30±0.5Vdc	60±1Vdc	400±5Vdc
	REVERSE POLARITY	No damage, re-power on to recover after fault condition is removed		By internal fuse open		
	AC OUTPUT	OVER TEMPERATURE	Shut down o/p voltage, recovers automatically after temperature goes down			
		OUTPUT SHORT	Shut down o/p voltage, re-power on to recover			
		OVER LOAD (Typ.)	105~115% load for 180 sec., 115%~140% load for 10 sec. 105 ~ 115% load for 180 sec., 115% ~ 150% load for 10 sec.			
CIRCUIT BREAKER		35A				
FUNCTION	REMOTE CONTROL	Power ON-OFF remote control by front panel dry contact connector(by RELAY) Open : Remote off ; Short : Normal work				
	COMMUNICATION	Modbus-RTU (RS-485) / CANBus				
AC UPS MODE	AC INPUT RANGE	200/220/230/240Vac±16%, recover±13%				
	FREQUENCY RANGE	45 ~ 65Hz				
	TRASFER TIME(Typ.)	10ms inverter — AC by pass				
AC CHARGER	BOOST CHARGE VOLTAGE	Default 28.8Vdc	Default 57.6Vdc	Default 400Vdc		
	FLOAT CHARGE VOLTAGE	Default 27.6Vdc	Default 55.2Vdc	Default 385Vdc		
	CHARGE VOLTAGE RANGE	20 ~ 30Vdc	40 ~ 60Vdc	290 ~ 400Vdc		
	CONSTANT CURRENT	135A	70A	11.3A		
	MAX. CHARGE POWER	4050W	4200W	4520W		
	TEMPERATURE COMPENSATION	By external NTC				
	POWER FACTOR (Typ.)	PF>0.98/230VAC at full load				
	EFFICIENCY (Typ.)	91%	93%	94%		
	AC CURRENT (Typ.)	25A/230VAC				
	INRUSH CURRENT (Typ.)	50A/230VAC				
LEAKAGE CURRENT(Peak)	4.7mA/264VAC					

ENVIRON- MENT	WORK TEMP.	-30 ~ +70°C (Refer to "Derating curve")			
	WORKING HUMIDITY	20 ~ 90% RH non-condensing			
	STORAGE TEMP., HUMIDITY	-30 ~ +70°C / -22 ~ +158°F, 10 ~ 95% RH non-condensing			
	VIBRATION	10 ~ 500Hz, 3G 10min./1cycle, 60min. each along X, Y, Z axes			
SAFETY & EMC (Note.4)	SAFETY STANDARDS	CB IEC62368-1, CSA C22.2 No. 62368-1, TUV BS EN/EN62368-1, AS/NZS 62368.1, EAC T/PTC 004 approved			
	WITHSTAND VOLTAGE	DC I/P - AC:3.0KVAC AC - FG:1.5KVAC			
	ISOLATION RESISTANCE	DC I/P - AC O/P, DC I/P - FG, AC O/P - FG: 100M ohms / 500VDC / 25°C / 70% RH			
	EMC EMISSION	Parameter	Standard	Test Level / Note	
		Radiated	BS EN/EN55032(CISPR32)	Class A	
		Conducted	BS EN/EN55032(CISPR32)	Class A	
		Harmonic Current	BS EN/EN61000-3-2	Class A	
		Voltage Flicker	BS EN/EN61000-3-3	-----	
	EMC IMMUNITY	BS EN/EN55024, BS EN/EN55035			
		Parameter	Standard	Test Level / Note	
ESD		BS EN/EN61000-4-2	Level 3, 8KV air ; Level 2, 4KV contact		
Radiated		BS EN/EN61000-4-3	Level 2		
EFT / Burst		BS EN/EN61000-4-4	Level 2, 1KV		
Surge		BS EN/EN61000-4-5	Level 3, 1KV/Line-Line 2KV/Line-Earth		
Conducted		BS EN/EN61000-4-6	Level 2		
Magnetic Field		BS EN/EN61000-4-8	Level 1		
Voltage Dips and Interruptions		BS EN/EN61000-4-11	>95% dip 0.5 periods, 30% dip 25 periods, >95% interruptions 250 periods		
OTHER		MTBF	200.9K hrs min. Telcordia TR/SR-332 (Bellcore) ; 17.8K hrs min. MIL-HDBK-217F (25°C)		
	DIMENSION	460*211*83.5mm (L*W*H)			
	PACKING	10.5Kg; 1pcs/ 10.5Kg/ 1.25CUFT			
NOTE	1.Efficiency, AC regulation and THDv are tested by 75% load, linear load at 25Vdc/50Vdc/400Vdc input voltage.				
	2.All parameters not specified above are measured at 25Vdc/50Vdc/400Vdc input and 25°C of ambient temperature and set to factory setting.				
	3.The tolerance of each voltage value by models is: 224 → ±0.5V; 248 → ±1V; 2380 → ±5V.				
	4.The power supply is considered as an independent unit, but the final equipment still need to re-confirm that the whole system complies with the EMC directives. For guidance on how to perform these EMC tests, please refer to "EMI testing of component power supplies." (as available on <a href="https://www.meanwell.com/Upload/PDF/EMI_statement_en.pdf">https://www.meanwell.com/Upload/PDF/EMI_statement_en.pdf</a> )				
※ Product Liability Disclaimer : For detailed information, please refer to <a href="https://www.meanwell.com/serviceDisclaimer.aspx">https://www.meanwell.com/serviceDisclaimer.aspx</a>					

MODEL		NTN-5K-124 <input type="checkbox"/>	NTN-5K-148 <input type="checkbox"/>		
		<input type="checkbox"/> =Blank, CAN			
AC OUTPUT	RATED POWER(Continuous)	4000W			
	OVER RATED POWER(3 Min.)	4600W			
	PEAK POWER(10 Sec.)	5600W	6000W		
	SURGE POWER(30 Cycles)	7000W	8000W		
	AC VOLTAGE	Default setting set at 110VAC 100 / 110 / 115 / 120Vac selectable by DIP S.W			
	FREQUENCY	Default setting set at 60Hz±0.1Hz 50/60Hz selectable by DIP S.W			
	WAVEFORM	Note.1 True sine wave (THDv<3%)			
AC REGULATION	±3.0% at rated input voltage				
DC INPUT	DC VOLTAGE	24Vdc	48Vdc		
	VOLTAGE RANGE (Typ.)	19 ~ 33Vdc	38 ~ 66Vdc		
	DC CURRENT (Typ.)	200A	100A		
	NO LOAD	NON-SAVING MODE	2.5A	1.4A	
	DISSIPATION (Typ.)	SAVING MODE	Default disable, auto detect AC output load ≤10W will be changed to saving mode <25W		
	OFF MODE CURRENT DRAW	≤2mA			
	EFFICIENCY (Typ.)	Note.1	89%	91%	
	BATTERY TYPES	Lead Acid or li-ion			
PROTECTION	DC INPUT	LOW	ALARM	22±0.5Vdc	44±1Vdc
			SHUTDOWN	19±0.5Vdc	38±1Vdc
			RESTART	25±0.5Vdc	50±1Vdc
		HIGH	ALARM	31±0.5Vdc	62±1Vdc
			SHUTDOWN	33±0.5Vdc	66±1Vdc
			RESTART	30±0.5Vdc	60±1Vdc
	REVERSE POLARITY	No damage, re-power on to recover after fault condition is removed			
	AC OUTPUT	OVER TEMPERATURE	Shut down o/p voltage, recovers automatically after temperature goes down		
		OUTPUT SHORT	Shut down o/p voltage, re-power on to recover		
		OVER LOAD (Typ.)	105 ~ 115% load for 180 sec., 115% ~ 150% load for 10 sec.		
CIRCUIT BREAKER		Protection type : Shut down o/p voltage, re-power on to recover 50A			
FUNCTION	REMOTE CONTROL	Power ON-OFF remote control by front panel dry contact connector(by RELAY) Open : Remote off ; Short : Normal work			
	COMMUNICATION	Modbus-RTU (RS-485) / CANBus			
AC UPS MODE	AC INPUT RANGE	100/110/115/120Vac±16%, recover±13%			
	FREQUENCY RANGE	45 ~ 65Hz			
	TRANSFER TIME(Typ.)	10ms inverter — AC by pass			
AC CHARGER	BOOST CHARGE VOLTAGE	Default 28.8Vdc	Default 57.6V		
	FLOAT CHARGE VOLTAGE	Default 27.6Vdc	Default 55.2Vdc		
	CHARGE VOLTAGE RANGE	20 ~ 30Vdc	40 ~ 60Vdc		
	CONSTANT CURRENT	120A	60A		
	MAX. CHARGE POWER	3600W	3600W		
	TEMPERATURE COMPENSATION	By external NTC			
	POWER FACTOR (Typ.)	PF>0.98/115VAC at full load			
	EFFICIENCY (Typ.)	89%	91%		
	AC CURRENT (Typ.)	20A/110VAC			
	INRUSH CURRENT (Typ.)	25A/110VAC			
LEAKAGE CURRENT(Peak)	4.7mA/264VAC				

ENVIRON- MENT	WORK TEMP.	-30 ~ +70°C (Refer to "Derating curve")			
	WORKING HUMIDITY	20 ~ 90% RH non-condensing			
	STORAGE TEMP., HUMIDITY	-30 ~ +70°C / -22 ~ +158°F, 10 ~ 95% RH non-condensing			
SAFETY & EMC (Note.4)	VIBRATION	10 ~ 500Hz, 3G 10min./1cycle, 60min. each along X, Y, Z axes			
	SAFETY STANDARDS	CB IEC62368-1, TUV BS EN/EN62368-1 approved			
	WITHSTAND VOLTAGE	DC I/P - AC:3.0KVAC	AC - FG:1.5KVAC		
	ISOLATION RESISTANCE	DC I/P - AC:100M Ohms	AC - FG: 500VDC / 25°C / 70% RH		
	EMC EMISSION	Parameter	Standard	Test Level / Note	
		Radiated	FCC	Class A	
Conducted		FCC	Class A		
OTHER	MTBF	200.9K hrs min.	Telcordia TR/SR-332 (Bellcore) ; 17.8K hrs min. MIL-HDBK-217F (25°C)		
	DIMENSION	460*211*83.5mm (L*W*H)			
	PACKING	10.5Kg; 1pcs/ 10.5Kg/ 1.25CUFT			
NOTE	<p>1.Efficiency, AC regulation and THDv are tested by 75% load, linear load at 25Vdc/50Vdc input voltage.</p> <p>2.All parameters not specified above are measured at 25Vdc/50Vdc/400Vdc input and 25°C of ambient temperature and set to factory setting.</p> <p>3.The tolerance of each voltage value by models is: 124→±0.5V; 148→±1V.</p> <p>4.The power supply is considered as an independent unit, but the final equipment still need to re-confirm that the whole system complies with the EMC directives. For guidance on how to perform these EMC tests, please refer to "EMI testing of component power supplies." (as available on <a href="https://www.meanwell.com/Upload/PDF/EMI_statement_en.pdf">https://www.meanwell.com/Upload/PDF/EMI_statement_en.pdf</a>)</p> <p>※ Product Liability Disclaimer : For detailed information, please refer to <a href="https://www.meanwell.com/serviceDisclaimer.aspx">https://www.meanwell.com/serviceDisclaimer.aspx</a></p>				

## 2.4 Derating Curve

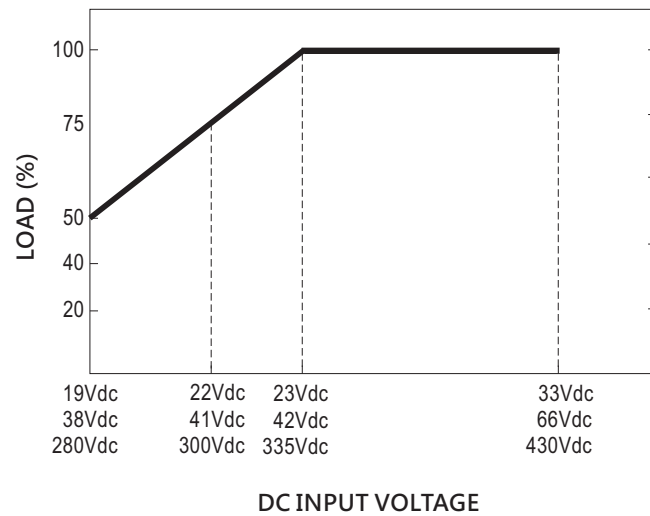
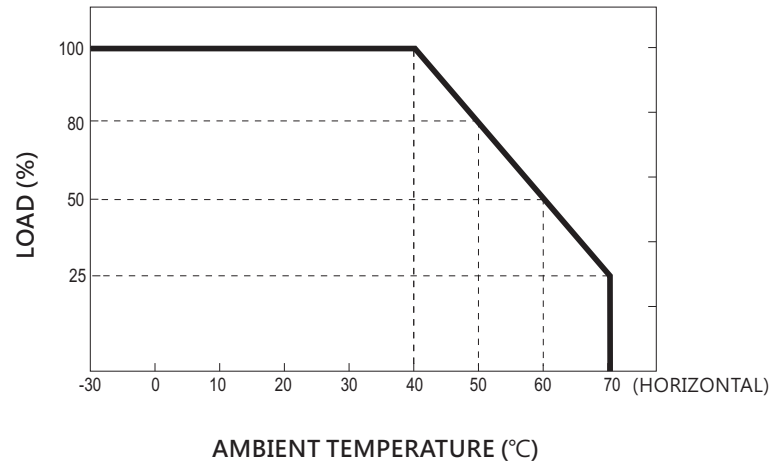

## 2.5 Mechanical Specification

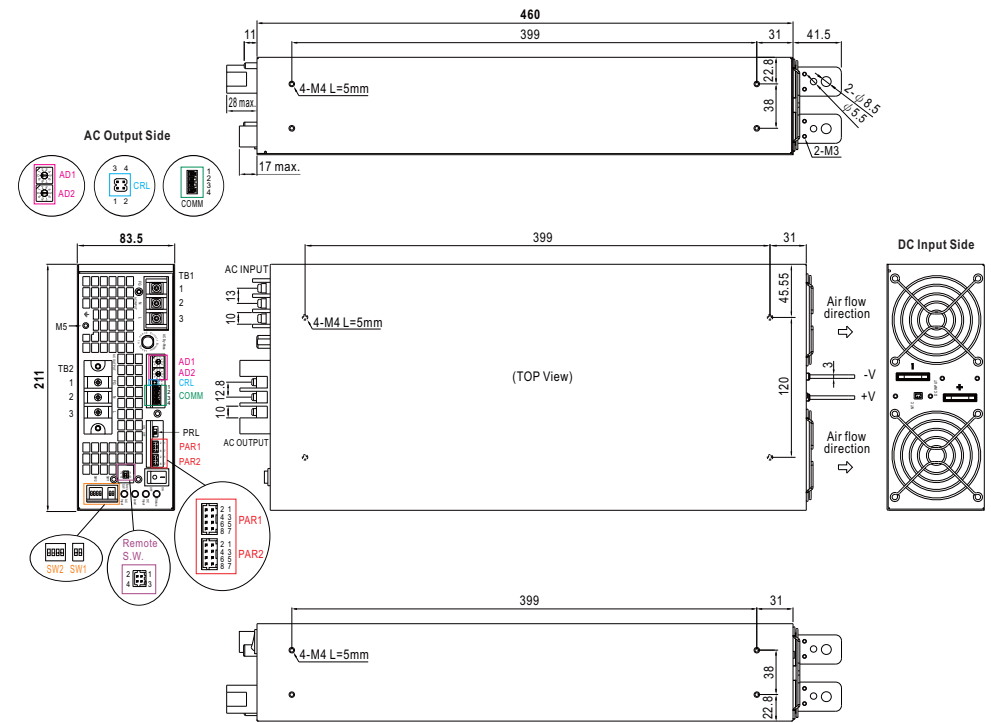

## Accessories

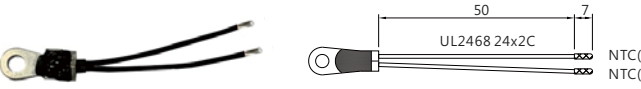
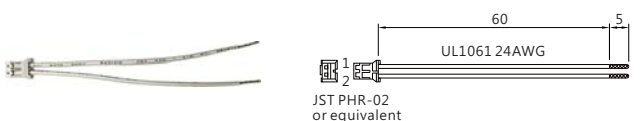
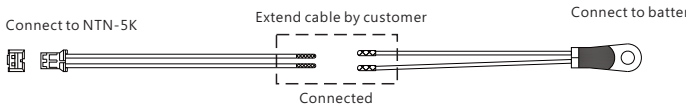

※ NTC Sensor and Remote Control mating along with NTN-5K (Standard accessory)

Item	Quantity
<p>①</p> <p>NTC sensor wire</p> 	1
<p>②</p> <p>NTC mating wire</p> 	1
<b>Connection Diagram</b>	
	

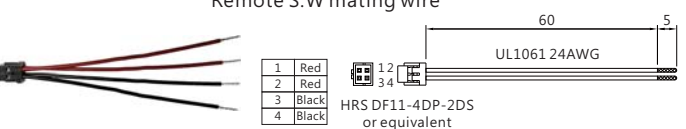
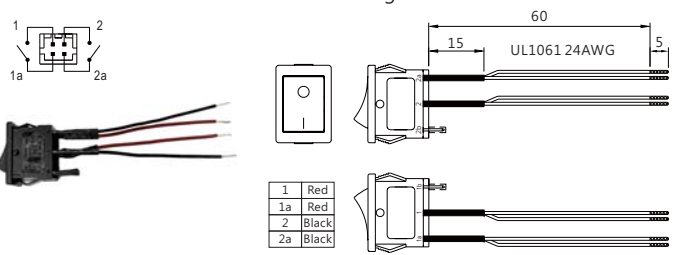
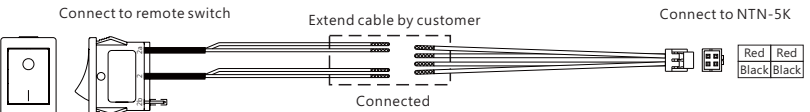
※ Remote Control mating along with NTN-5K (Standard accessory)

Item	Quantity
<p>①</p> <p>Remote S.W mating wire</p> 	1
<p>②</p> <p>Remote S.W mating wire</p> 	1
<b>Connection Diagram</b>	
	

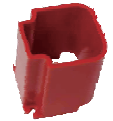
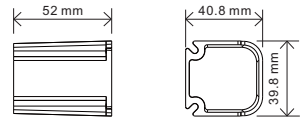
※ Terminal protector mating along with NTN-5K (Standard accessory)

Item	Quantity
<p>①</p>  	1
<p>②</p> 	1
<p>③</p> 	4

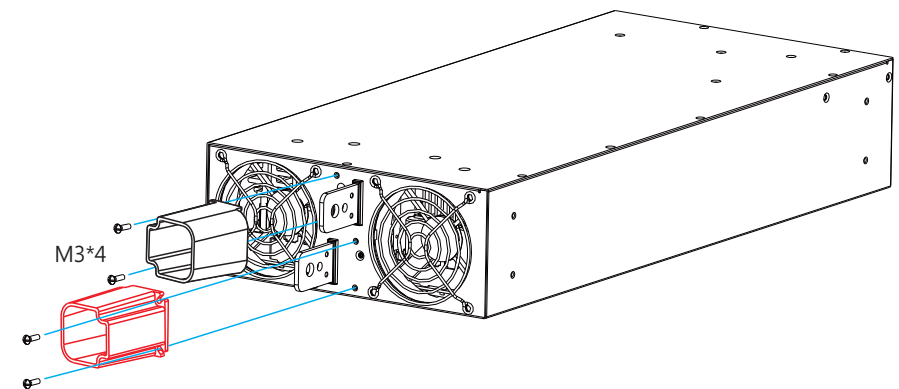



### 3.Installation & Wiring

#### 3.1 Precautions

- The unit should be mounted on a flat surface or holding rack with suitable strength.
- In order to ensure the lifespan of the unit, you should refrain from operating the unit in environments with high dust or moisture.
- NTN-5K is designed with built-in DC fans. Please make sure that the ventilation is not blocked. We recommend that there should be no barriers within 15cm of the ventilation slits, as shown below.

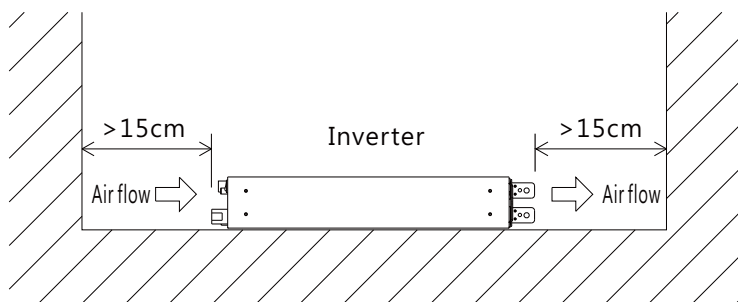

Figure 3-1 Arrangement suggestion

#### 3.2 System Block Diagram

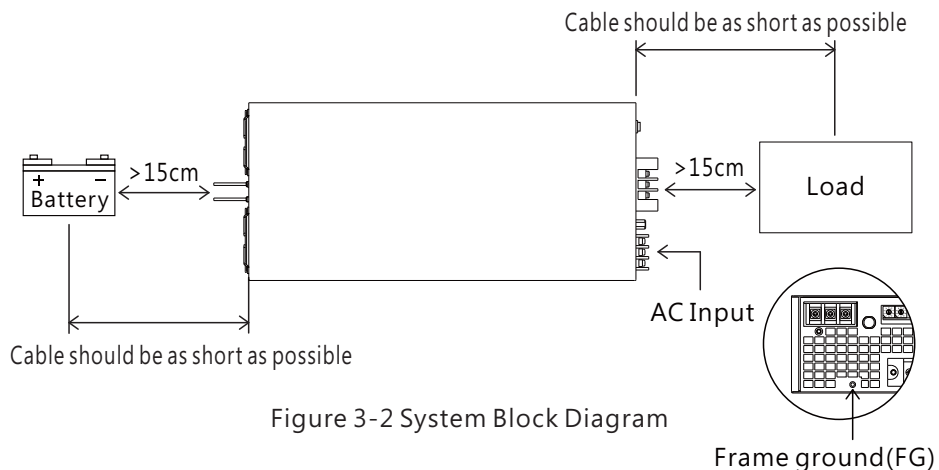
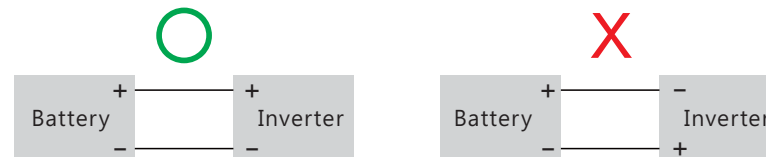

Figure 3-2 System Block Diagram

#### 3.3 Installation Procedures

- ① Turn the inverter off by switching the Main S.W. to the OFF position.
- ② Select appropriate cables for connection between the battery and the inverter. Please refer to Section 3.4 for wiring guidance.
- ③ Connect the battery to the DC input terminals of the inverter. Attach the positive terminal (+) of the battery to the positive input terminal (+) and connect the negative terminal (-) of the battery to the negative input terminal (-). Please ensure not to reverse the polarity or create a short circuit.



- ④ Turn the Main S.W. switch to the ON position. The status indicator should start flashing in green and then display a steady green light, indicating normal operation.

#### 3.4 Battery Wiring Selection

Wire connections should be as short as possible and less than 1.5 meter is highly recommended. Make sure that suitable wires are chosen based on safety requirement and rating of current. Small cross section will result in reduced efficiency or inability to achieve full power output and may also lead to overheating and fire hazards. Please refer to table 3-1.

Rated current (A)	Cross section(mm <sup>2</sup> )	AWG
40A	4	10
63A	6	8
80A	10	6
100A	16	4
125A	25	2
160A	35	1
190A	50	0
230A	70	000
260A	75	0000

Table 3-1 Cable Recommendation

#### 3.5 Battery Selection

Model/Output	124	224	148	248	2380
NTN-5K	800Ah or above	400Ah or above	400Ah or above	54Ah or above	

## 4. User Interface

### 4.1 AC Panel

#### Ⓐ AC bypass input terminals:

When AC mains power or utility is available, connecting the input to the AC mains will activate the AC bypass function. This allows the AC energy to feed the load directly from the AC mains and also charge the battery simultaneously.

M4 screws are used; Recommended cable size: 10 - 18 AWG; Recommended torque: 18kgf-cm.

#### Ⓑ Miniature circuit breaker (MCB):

In bypass mode, if the AC output is short-circuited or the load current exceeds the rated current of the MCB, the MCB will trip, disconnecting from the AC output and stopping the direct feed from the mains to prevent potential hazards. Once the abnormal condition is resolved, the user can press the reset button to resume bypass operation.

#### Ⓒ AD1,AD2:

Serve as the device address setting for communication purposes. Please refer to Section 4.6 for details.

#### Ⓓ CRL:

Termination resistor, used to stabilize the Modbus / CAN Bus communication and eliminate signals refraction.

#### Ⓔ COMM:

The Modbus-RTU / CAN Bus communication port.

#### Ⓕ AC output terminals:

M4 screws are used; Recommended cable size: 8 - 18 AWG; Recommended torque: 18kgf-cm.

#### Ⓖ PRL,PAR1,PAR2 and Remote ON-OFF

Serve as stable signals for multiple NTN-5K units connected in parallel.

#### Ⓗ Main Switch:

The inverter powers on if the switch is in the ON position; the inverter powers off if the switch is in the OFF position.

#### Ⓘ LED Indicators:

Indicate the status and the load condition of the inverter.

#### Ⓙ Remote Switch:

The same function as Main S.W. but can be used remotely. Please refer to Section 5.4 For details.

#### Ⓚ SW1:

Three-phase connection selection switch. Please refer to Section 5.3 for details.

#### Ⓛ SW2:

Voltage/Frequency selection switch. Please refer to Section 5.1 for details.

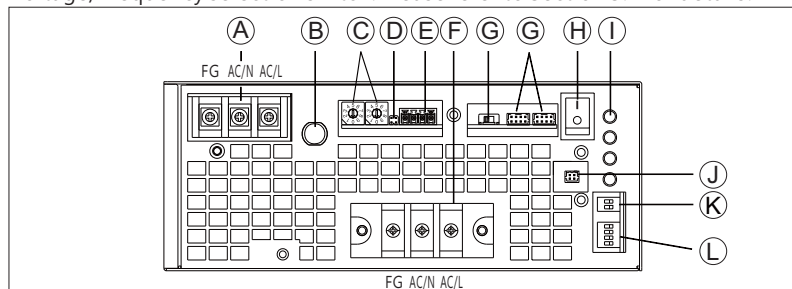

### 4.2 DC Panel

#### Ⓐ Ventilation slits:

To ensure proper operation and preserve the lifespan of the inverter, please ensure suitable ventilation is provided.

#### Ⓑ DC input terminals(+),(-):

M8 screws are used; Please refer to Section 3.4 for cable suggestion.

#### Ⓒ NTC:

Used for battery temperature compensation. Please refer to Section 5.6.4 for details.

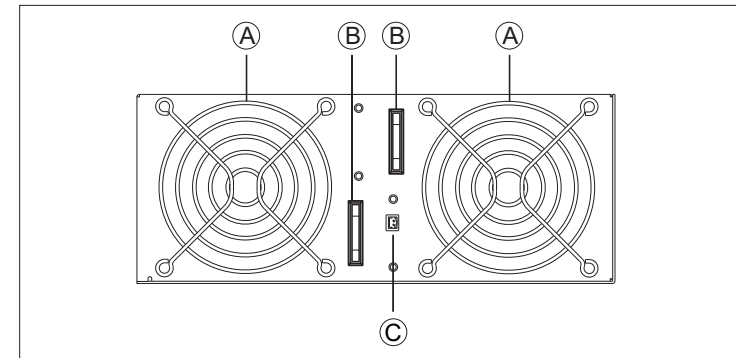

### 4.3 LED Indicators

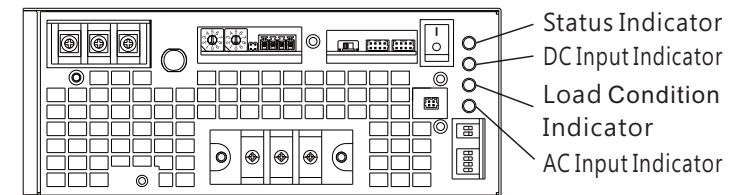

#### Status Indicator:

The LED is used to indicate the status of inverter, including inverter OK, remote on/off and power saving mode.

During the initial startup procedure, the Status Indicator will flash a green light to indicate that the inverter is undergoing system check. Once the process is completed, the Status Indicator will change to a steady green, indicating normal operation.

Status	Green	Orange	Red
	<ul style="list-style-type: none"> <li>Inverter OK</li> <li>System check</li> </ul>	<ul style="list-style-type: none"> <li>Remote off</li> <li>Saving mode</li> </ul>	<ul style="list-style-type: none"> <li>Abnormal Status (See below table)</li> </ul>

Note: The inverter will initiate a system check procedure when it is powered on or switched to inverter mode by Remote off/on.

### DC Input Indicator:

It is used to show the input status of inverter.

Green light : When input voltage is greater than 25V(24V)/50V(48V)/335V(380V).

Orange light: When input voltage is within a range of 22V~25V(24V)/44V~50V(48V)/300V~335V(380V).

Red light : When input voltage is lower than 22V(24V)/44V(48V)/300V(380V) or over its specification. It flashes and a warning sound will be activated.

	Green	Orange	Red
DC Input	● 25~31Vdc	● 22~25Vdc	● <22Vdc or >31Vdc
	● 50~62Vdc	● 44~50Vdc	● <44Vdc or >62Vdc
	● 335~420Vdc	● 300~335Vdc	● <300Vdc or >420Vdc
	☀️ Maintain	☀️ Charging	

### Load Condition Indicator :

1. Displaying the load status in use.

Green light : Indicates the light load status when the load is less than 40%.

Orange light: Indicates the medium load status when the load is between 40% and 80%.

Red light : Indicates the heavy load status when the load exceeds 80%.

Additionally, when the load exceeds 100%, a warning sound will also be activated.

Load	Green	Orange	Red
Inverter Mode	● <40% load	● 40~80% load	● >80% load
Bypass Mode	☀️ <40% load	☀️ 40~80% load	☀️ >80% load

2. Displaying the status of Bypass or Inverter in Energy-saving Mode.

	Green	Orange	Red
Bypass (Energy-saving Mode)	☀️ <40% load	☀️ 40~80% load	☀️ >80% load
Inverter (Energy-saving Mode)	● <40% load	● 40~80% load	● >80% load

### AC Input Indicator :

Used to display the status of the AC mains.

Green light : When the AC mains is connected and the voltage is present normally.

Flash in green light: When the AC mains is connected but the voltage exceeds  $\pm 10\%$  of the rated voltage, the green light will start flashing for warning.

Light off : When the AC mains is disconnected or not connected, LED will be off.

	Green	
AC Input	● Utility OK	● Steady
	☀️ Utility error	☀️ Flashing
	○ Utility disconnected	○ Light off

Note: During the initial startup procedure, if there is input from the AC mains detected, the inverter will verify whether the AC voltage and frequency match the internal set values. The AC Input Indicator will flash a green light during this procedure.

## 4.4 Pin Assignment of CRL

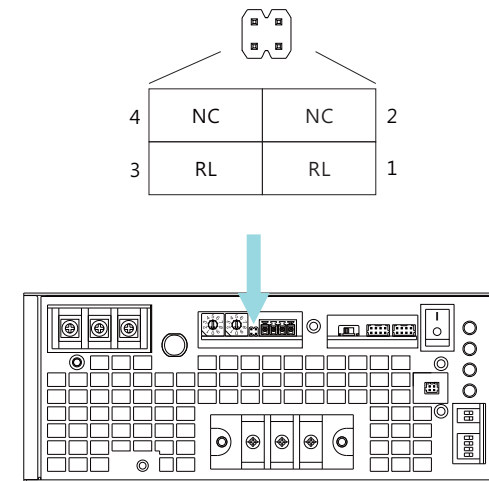

### Connector Pin No. Assignment:

Pin No.	Function	Description
1,3	RL	Short: Termination resistors(120Ω) For MODBus/CANBus communication, please use Jumper (pin1,3)
2,4	NC	No need to communicate, please use Jumper (pin2,4)

Note: AD1,AD2 switch for MODBus/CANBus interface address setting, please refer to the user manual for more details

## 4.5 Pin Assignment of COMM

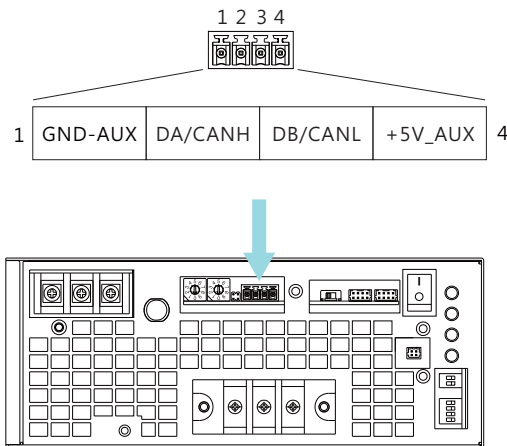

## 4.6 Pin Assignment of PAR1,PAR2

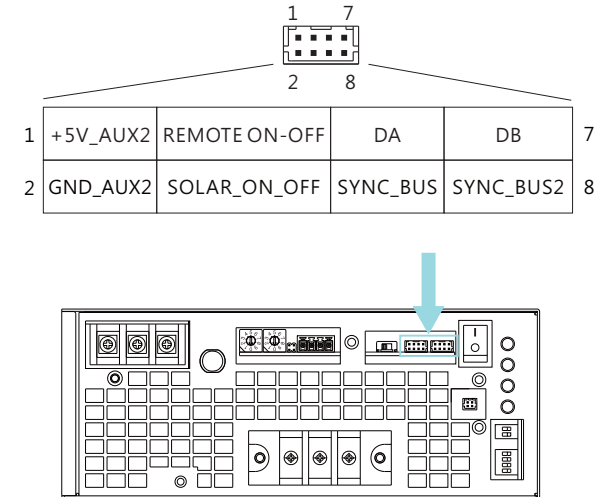

Connector Pin No. Assignment: EC381V-04P or equivalent

Pin No.	Function	Description
1	GND-AUX	Auxiliary voltage output GND.
2	D+/CANH	For Modbus model: Data line used in Modbus interface.
		For CAN Bus model: Data line used in CAN Bus interface.
3	D-/CANL	For Modbus model: Data line used in Modbus interface.
		For CAN Bus model: Data line used in CAN Bus interface.
4	+5V_AUX	Auxiliary voltage output, 4.5~5.5V, referenced to GND-AUX (pin1)

Note: The same function as Main S.W. but can be used remotely.  
Please refer to Section 5.4 For details.

Connector Pin No. Assignment: HRS DF11-08DP-2DS or equivalent

Pin No.	Function	Description
1	+5V_AUX2	Auxiliary voltage output, 4.5~5.5V, referenced to GND-AUX (pin2). (Only for REMOTE ON-OFF)
2	GND_AUX2	Auxiliary voltage output GND_AUX2 (pin2).
3	REMOTE ON-OFF	The unit can turn the output ON/OFF by dry contact between Remote ON/OFF and +5V_AUX2.(Note) Short: Power ON ; Open: Power OFF
4	SOLAR_ON_OFF	External MPPT charger control, referenced to GND_AUX2 (pin2).
5	DA	Data line used for parallel control.
6	SYNC_BUS	Phase synchronization used for parallel control.
7	DB	Data line used for parallel control.
8	SYNC_BUS2	Mode synchronization used for parallel control.

Note: Isolated signal, referenced to GND\_AUX2

## 4.7 Pin Assignment of Remote Switch

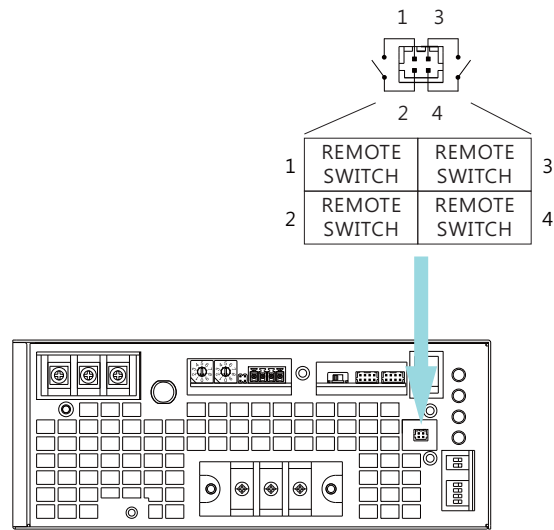

Connector Pin No. Assignment: HRS DF11-04DP-2DS or equivalent

Pin No.	Function	Description
1,2,3,4	REMOTE SWITCH	The unit can be remotely turned the output ON/OFF by dry contact between Pin1,2 & 3,4. Power ON : Short Pin1 to 2 and Pin3 to 4 ; Power OFF : Pin1 ~ Pin4 open.

## 4.8 Communication Address/ID Assignment

Each NTN-5K unit should have their unique and own device address to communicate over the bus. AD1 and AD2 allow users to designate an address/ID for the Modbus/CAN bus (with maximum of 64 addresses). Please refer to the table below for detailed settings.

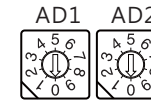

Address/ID	Switch position	
	AD1	AD2
0	0	0
1	0	1
2	0	2
3	0	3
4	0	4
5	0	5
6	0	6
7	0	7
8	0	8
9	0	9
10	1	0
11	1	1
12	1	2
13	1	3
14	1	4
15	1	5
16	1	6
17	1	7
18	1	8
19	1	9
20	2	0
21	2	1
22	2	2
23	2	3
24	2	4
25	2	5
26	2	6
27	2	7
28	2	8
29	2	9
30	3	0
31	3	1

Address/ID	Switch position	
	AD1	AD2
32	3	2
33	3	3
34	3	4
35	3	5
36	3	6
37	3	7
38	3	8
39	3	9
40	4	0
41	4	1
42	4	2
43	4	3
44	4	4
45	4	5
46	4	6
47	4	7
48	4	8
49	4	9
50	5	0
51	5	1
52	5	2
53	5	3
54	5	4
55	5	5
56	5	6
57	5	7
58	5	8
59	5	9
60	6	0
61	6	1
62	6	2
63	6	3

## 5. Explanation of Operation

### 5.1 Procedure of Setting Output voltage, Frequency and Saving Mode

#### 5.1.1 Output Voltage and Frequency Setting

Factory settings are either 110Vac/60Hz or 230Vac/50Hz. Users can adjust the voltage and frequency through the DIP switches of SW2 on the AC panel. S1/S2 are used for voltage adjustment, and SW3 is for frequency adjustment. Please refer to the table below.

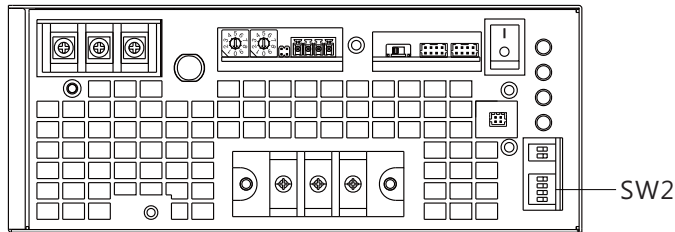

AC Output Voltage, Frequency, Saving Mode selectable by the SW2			
S1	S2	S3	S4
OFF	OFF : 100Vac or 200Vac	ON : 50Hz	ON : Saving Mode
OFF	ON : 110Vac or 220Vac		
ON	OFF : 115Vac or 230Vac	OFF: 60Hz	OFF: Non-Saving Mode
ON	ON : 120Vac or 240Vac		

#### 5.1.2 Saving Mode Setting

To prevent unnecessary battery energy discharge when the inverter is not connected to a load, the Saving Mode function can be activated to reduce further power consumption from the inverter, which is to set S4 of SW2 to the on position. In Saving Mode, if the inverter detects no load (< 10W) for 3 seconds, it will shut off its output. It will then periodically check the output load status to switch back. If a load greater than 25W is detected or connected, the inverter will return to normal operation and provide AC energy.

### 5.2 Parallel Synchronized Operation (Single-phase Parallel)

NTN-5K has the built-in active current sharing function and can be connected in parallel, up to 6 units, to provide higher output power as exhibited below:

- ✘The output voltage and frequency settings must be the same for all units.
- ✘The inverter should be paralleled using short and large diameter wiring and then connected to the load.
- ✘The total output current must not exceed the value determined by the following equation:

Maximum output current at parallel operation = (Rated current per unit) x (Number of unit) x 95% ; when parallel unit less than 6.

#### ✘ PAR1/PAR2, PRL Function pin connection

Parallel	PSU1		PSU2		PSU3		PSU4		PSU5		PSU6	
	PAR1	PRL	PAR1	PRL	PAR1	PRL	PAR1	PRL	PAR1	PRL	PAR1	PRL
1 unit	X	ON	—	—	—	—	—	—	—	—	—	—
2 unit	V	ON	V	ON	—	—	—	—	—	—	—	—
3 unit	V	ON	V	OFF	V	ON	—	—	—	—	—	—
4 unit	V	ON	V	OFF	V	OFF	V	ON	—	—	—	—
5 unit	V	ON	V	OFF	V	OFF	V	OFF	V	ON	—	—
6 unit	V	ON	V	OFF	V	OFF	V	OFF	V	OFF	V	ON

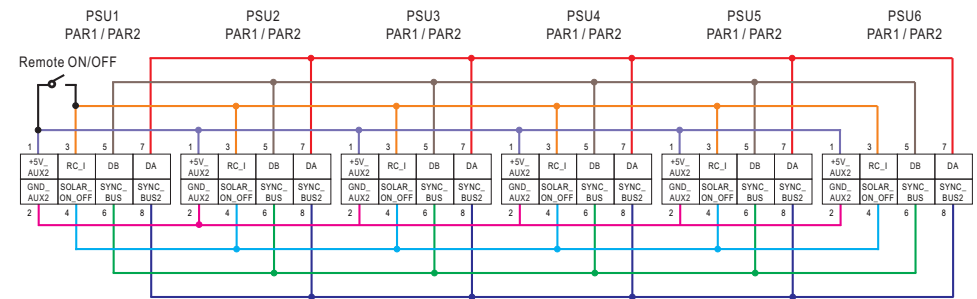
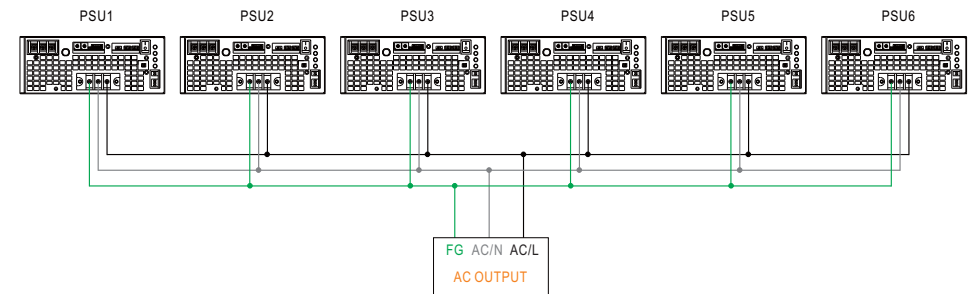

If the lines of PAR1 / PAR2 are too long, they should be twisted in pairs to avoid the noise.

## 5.3 Three-phase 4-wire Output

### 5.3.1 Three-phase 4-wire Output Setting

Users can connect three units of NTN-5K to form a three-phase 4-wire output, providing three AC voltage sources with equal voltage, the same frequency, but a phase difference of  $120^\circ$ .

NOTE:

1. The output voltage and frequency settings must be the same for the three units.
2. It is recommended to power on the unit with the L1,  $0^\circ$  setting first.
3. Attention should also be paid to the connection method of the input terminals. Please refer to the illustration of Arrangement for the AC input below.
4. If power rating needs to be increased, NTN-5K units should be configured according to section 5.3.3.

### Arrangement for the AC Output

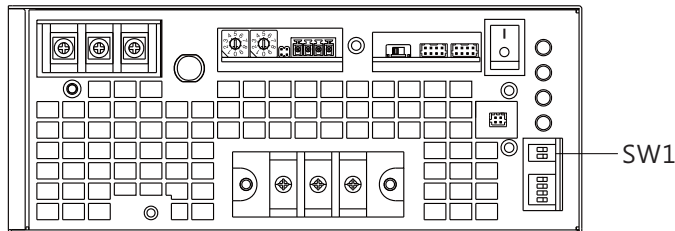
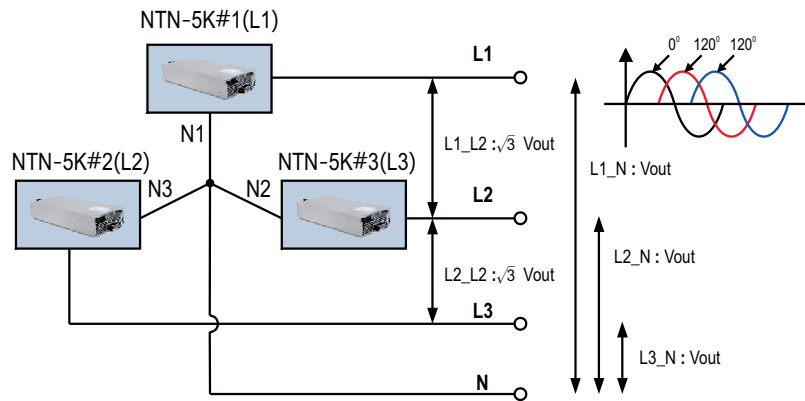

S1	S2	AC output phase
OFF	OFF	L1, $0^\circ$
OFF	ON	L2, $+120^\circ$
ON	OFF	L3, $-120^\circ$

### Arrangement for the AC input

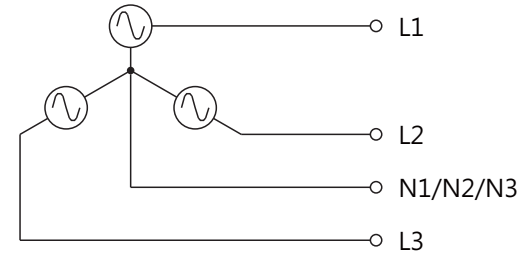

### 5.3.2 Configuration for Three-phase 4-wire Output

#### PAR1/PRL S.W

Quantity	L1 phase		L2 phase		L3 phase	
	PSU1		PSU2		PSU3	
	PAR1	PRL	PAR1	PRL	PAR1	PRL
3 units	V	ON	V	OFF	V	ON

L1 phase/SW1		L2 phase/SW1		L3 phase/SW1	
S1	S2	S1	S2	S1	S2
OFF	OFF	OFF	ON	ON	OFF

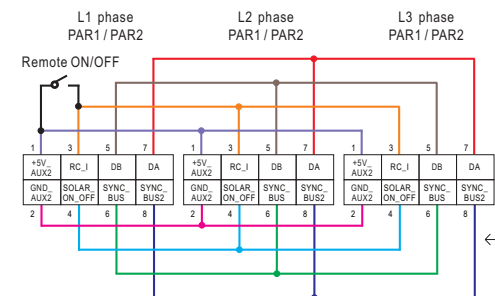
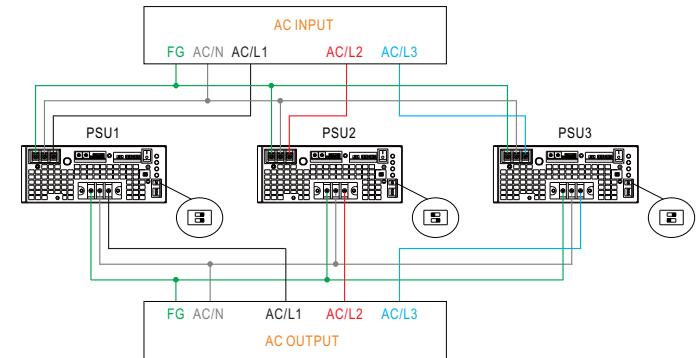

If the lines of PAR1 / PAR2 are too long, they should be twisted in pairs to avoid the noise.

### 5.3.3 Expansion Power Output Setting for Three-phase 4-wire Configuration

In addition to connecting three units of NTN-5K for a three-phase 4-wire output, users can also increase the output power of the three-phase 4-wire configuration. The maximum expansion per phase can be increased to 30KVA.

- ※ The output voltage and frequency settings must be the same for all units.
- ※ The inverter should be paralleled using short and large diameter wiring and then connected to the load.
- ※ The total output current must not exceed the value determined by the following equation:

$$\text{Maximum output current per phase} = (\text{Rated current per unit}) \times (\text{Number of unit}) \times 95\% ; \text{ when parallel unit less than 6.}$$

◎ Instructions for connecting TWO units of NTN-5K per phase, connections and settings for PAR1/PRL are as follows:

Quantity	L1 phase		L2 phase				L3 phase					
	PSU1		PSU2		PSU3		PSU4		PSU5		PSU6	
	PAR1	PRL	PAR1	PRL	PAR1	PRL	PAR1	PRL	PAR1	PRL	PAR1	PRL
6 units	V	ON	V	OFF	V	OFF	V	OFF	V	OFF	V	ON

L1 phase/SW1		L2 phase/SW1		L3 phase/SW1	
S1	S2	S1	S2	S1	S2
OFF	OFF	OFF	ON	ON	OFF

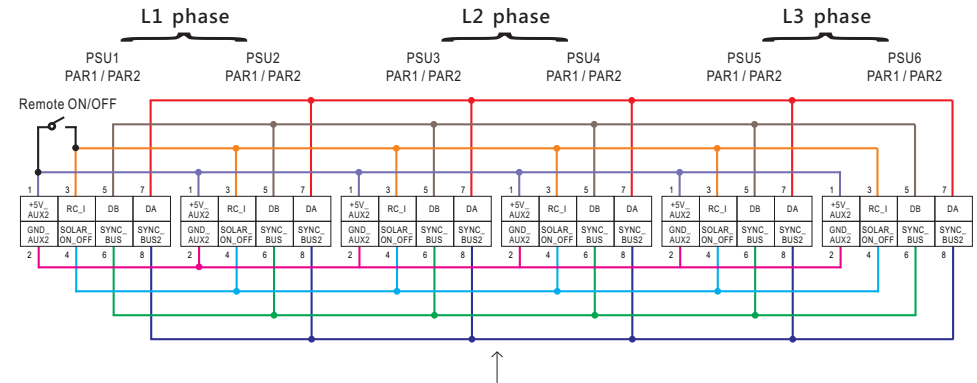
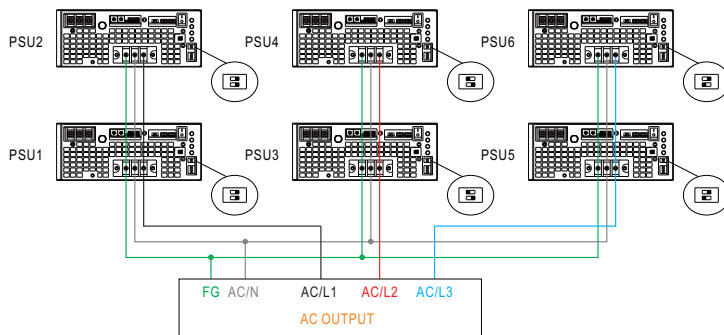

If the lines of PAR1 / PAR2 are too long, they should be twisted in pairs to avoid the noise.

◎ Instructions for connecting THREE units of NTN-5K per phase, connections and settings for PAR1/PRL are as follows:

Quantity	L1 phase		L2 phase				L3 phase					
	PSU1		PSU3		PSU4		PSU6		PSU7		PSU9	
	PAR1	PRL	PAR1	PRL	PAR1	PRL	PAR1	PRL	PAR1	PRL	PAR1	PRL
9 units	V	ON	V	OFF	V	OFF	V	OFF	V	OFF	V	ON

NOTE: Please refer to the instructions for connecting TWO units for the connection method of PAR1/PAR2 and the settings for SW1. Please also ensure that all signals of PAR1/PAR2 are connected to each others in a three-phase 4-wire configuration.

◎ Instructions for connecting FOUR units of NTN-5K per phase, connections and settings for PAR1/PRL are as follows:

Quantity	L1 phase		L2 phase				L3 phase					
	PSU1		PSU4		PSU5		PSU8		PSU9		PSU12	
	PAR1	PRL	PAR1	PRL	PAR1	PRL	PAR1	PRL	PAR1	PRL	PAR1	PRL
12 units	V	ON	V	OFF	V	OFF	V	OFF	V	OFF	V	ON

NOTE: Please refer to the instructions for connecting TWO units for the connection method of PAR1/PAR2 and the settings for SW1. Please also ensure that all signals of PAR1/PAR2 are connected to each others in a three-phase 4-wire configuration.

◎ Instructions for connecting FIVE units of NTN-5K per phase, connections and settings for PAR1/PRL are as follows:

Quantity	L1 phase		L2 phase				L3 phase					
	PSU1		PSU5		PSU6		PSU10		PSU11		PSU15	
	PAR1	PRL	PAR1	PRL	PAR1	PRL	PAR1	PRL	PAR1	PRL	PAR1	PRL
15 units	V	ON	V	OFF	V	OFF	V	OFF	V	OFF	V	ON

NOTE: Please refer to the instructions for connecting TWO units for the connection method of PAR1/PAR2 and the settings for SW1. Please also ensure that all signals of PAR1/PAR2 are connected to each others in a three-phase 4-wire configuration.



© Instructions for connecting SIX units of NTN-5K per phase, connections and settings for PAR1/PRL are as follows:

Quantity	L1 phase						L2 phase						L3 phase					
	PSU1		...	PSU6		PSU7		...	PSU12		PSU13		...	PSU18				
	PAR1	PRL		PAR1	PRL	PAR1	PRL		PAR1	PRL	PAR1	PRL		PAR1	PRL			
18 units	V	ON		V	OFF	V	OFF		V	OFF	V	OFF		V	ON			

NOTE: Please refer to the instructions for connecting TWO units for the connection method of PAR1/PAR2 and the settings for SW1. Please also ensure that all signals of PAR1/PAR2 are connected to each others in a three-phase 4-wire configuration.

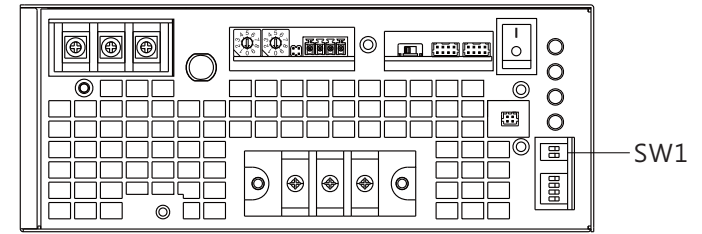

S1	S2	AC output phase
OFF	OFF	L1, 0°
ON	ON	L2, +180°

## 5.4 Single-phase 3-wire Output (124/148 only)

### 5.4.1 Single-phase 3-wire Output Setting

Users can connect two units of NTN-5K-1xx to form a single-phase 3-wire output, which doubles the AC voltage output of a single inverter unit while maintaining the same frequency.

For instance: Two inverter units that generate 110Vac/60Hz each can provide up to 220Vac/60Hz between the live terminals of L1 and L2.

NOTE:

1. The output voltage and frequency settings must be the same for both units.
2. It is recommended to power on the units simultaneously.
3. Pay close attention to the connection method of the AC input if the AC bypass function is needed. Please refer to section 5.4.2.
4. If the power rating needs to be increased, NTN-5K units should be configured according to section 5.4.4.

Arrangement for the AC Output

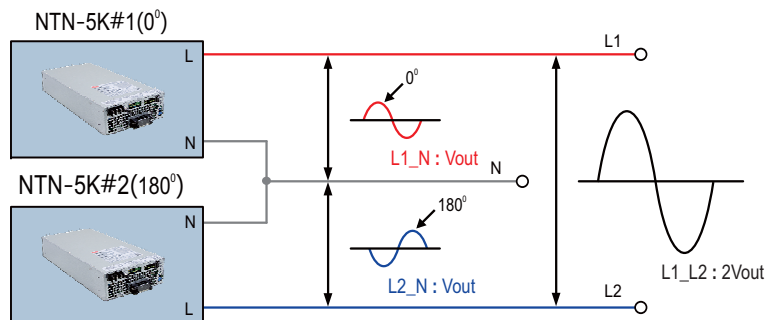

### 5.4.2 Input Connection for Single-phase 3-wire

The AC input for inverters in a single-phase 3-wire setting requires the phases to differ by 180 degrees in order to be connected. Therefore, this configuration cannot be directly connected to the mains electricity. The AC input must be connected through appropriate equipment, such as a center-tapped transformer.

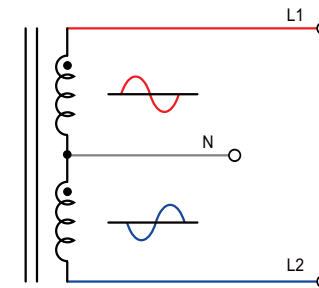

### 5.4.3 Configuration for Single-phase 3-wire

#### ◎ PAR1/PRL S.W

Quantity	0°		180°	
	PSU1		PSU2	
	PAR1	PRL	PAR1	PRL
2 units	V	ON	V	ON

0°/SW1		180°/SW1	
S1	S2	S1	S2
OFF	OFF	ON	ON

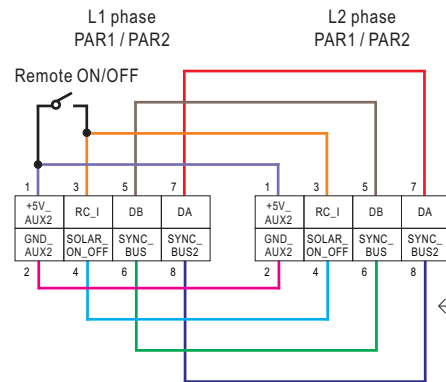
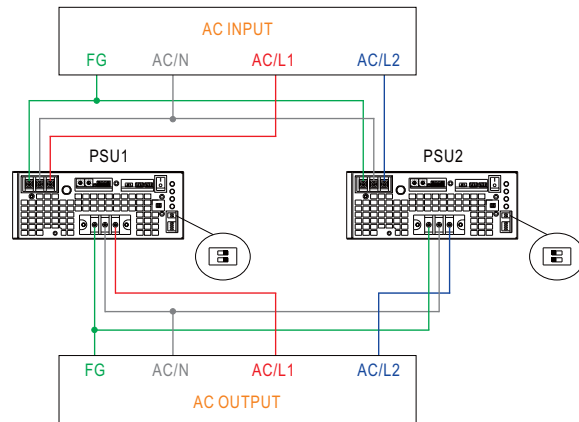

← If the lines of PAR1 / PAR2 are too long, they should be twisted in pairs to avoid the noise.

### 5.4.4 Expansion Power Output Setting for Single-phase 3-wire Configuration

In addition to connecting two units of NTN-5K for a single-phase 3-wire output, users can also increase the output power rating of this configuration. The maximum power can be increased up to 24KVA.

- ※ The output voltage and frequency settings must be the same for all units.
- ※ The inverters should be paralleled using short, large-diameter wiring before being connected to the loads.
- ※ The total output current must not exceed the value determined by the following equation: Maximum output power = (Rated power per unit) x (Number of unit) x 95%.

#### ◎ Instructions for connecting 6 units of NTN-5K per degree, connections and settings for PAR1/PRL are as follows:

Quantity	PSU1		PSU2		PSU3		PSU4		PSU5		PSU6	
	PAR1	PRL	PAR1	PRL	PAR1	PRL	PAR1	PRL	PAR1	PRL	PAR1	PRL
6 units	V	ON	V	OFF	V	OFF	V	OFF	V	OFF	V	ON

0°/SW1		180°/SW1	
S1	S2	S1	S2
OFF	OFF	ON	ON

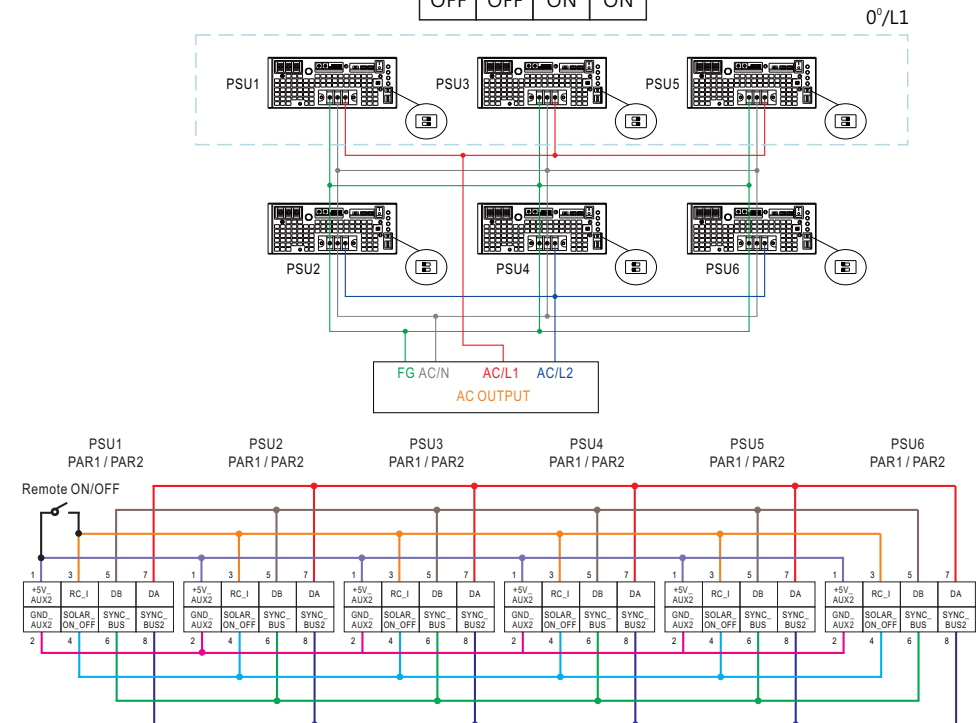

↑ If the lines of PAR1 / PAR2 are too long, they should be twisted in pairs to avoid the noise.

## 5.5 Remote ON-OFF Control

The remote ON-OFF control for the inverter can be divided into Remote Switch and Remote ON-OFF. The detailed description is as follows.

### 5.5.1 Remote Switch

The function of Remote Switch is identical to that of the Main S.W., the logic operation between the Remote Switch and the Main S.W. is shown in the table below. When both the Remote Switch and Main S.W. are set to OFF, the inverter enters a completely shut-down state, with no internal circuitry operation. Even if the AC input of the inverter is connected to the AC mains, it will not perform bypass functionality nor charge the battery.

Table for the logic operation between the Remote Switch and the Main S.W.:

Remote Switch	Main S.W.	Inverter state
OFF	OFF	Shut-down
ON	OFF	Operation
OFF	ON	Operation
ON	ON	Operation

Operation description of Remote Switch:

Remote Switch	Inverter state
Pin 1 to pin 2 shorted; Pin 3 to pin 4 shorted	Operation
Pin 1 to pin 2 opened; Pin 3 to pin 4 opened	Shut-down

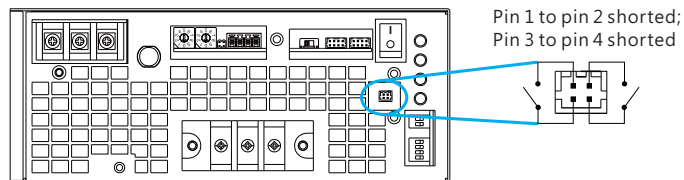

**NOTE: Risk of inverter damage:** Each inverter should have its independent switch used for the Remote Switch function. Sharing the same switch for Remote Switch among multiple inverters is prohibited.

### 5.5.2 Remote ON-OFF

The Remote ON-OFF function sets the inverter into standby mode. During this state, internal circuitry such as the MCU operates normally, while only the AC output is deactivated. If AC mains power is supplied to the inverter at this time, it will simultaneously charge the battery.

(Power consumption for the standby mode is approximately 20W)

PAR1/PAR2	Remote ON-OFF	AC Output Status
PIN1 and PIN3	Short	Power inverter ON
PIN1 and PIN3	Open	Power inverter OFF

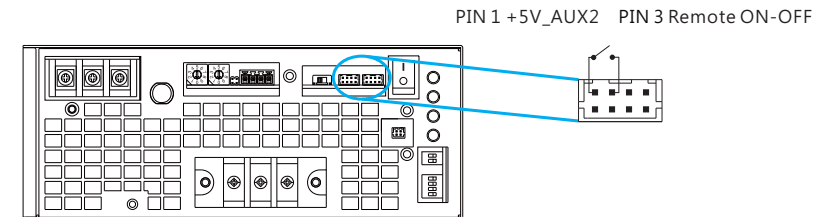

**NOTE:** Remote ON-OFF can only be activated when either the Main S.W. or the Remote Switch is set to ON.

## 5.6 Explanation of Operating Logic

The NTN-5K is a digital intelligent DC/AC sine wave inverter with two operating modes: UPS (Uninterruptible Power Supply) and Energy-saving Mode. It is set to UPS Mode by default, but users have the flexibility to switch to Energy-saving Mode based on difference applications through the communication protocol.

The main difference between UPS Mode and Energy-saving Mode is the level of energy saving. In UPS Mode, when the utility power is available, the NTN-5K operates in bypass mode, supplying power directly from the utility to the load, resulting in lower energy savings (please refer to Figure 5.1 Diagram of UPS mode control logic for details).

Both UPS Mode and Energy-saving Mode can be reconfigured via INV\_CONFIG (0x0101) command. For detailed instructions, please refer to Chapter 6.

### 5.6.1 Explanation of UPS Mode

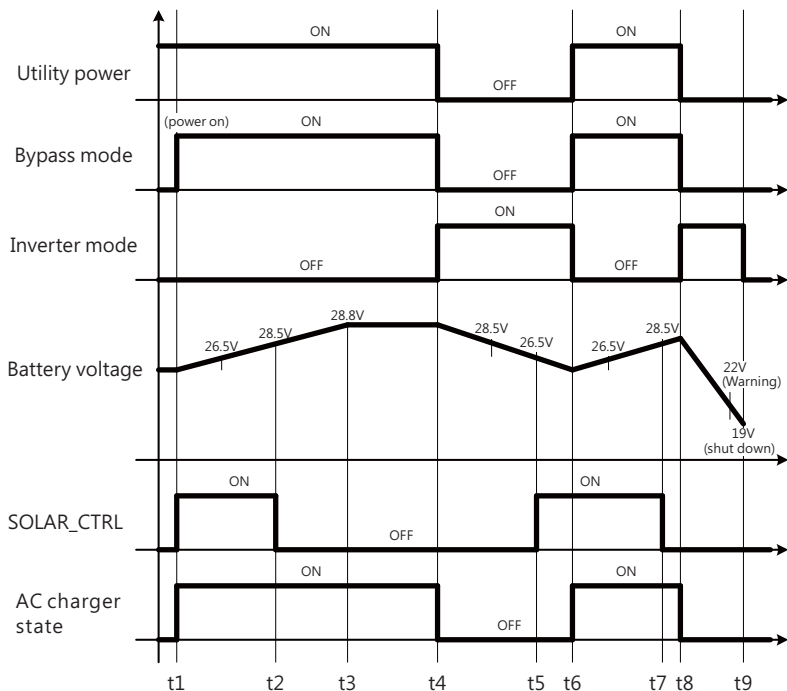

Figure 5.1 Diagram of UPS Mode control logic

Table 5-1 Indicator table of UPS Mode

	t1-t2	t2-t3	t3-t4	t4-t5	t5-t6	t6-t7	t7-t8	t8-t9	t9~
Status	●	●	●	●	●	●	●	●	●
DC input	☀	☀	☀	●	●→●	☀	☀	●→●→●	☀
Load signal	☀	☀	☀	●	●	☀	☀	●	○
AC input	●	●	●	○	○	●	●	○	○

NOTE:1. The color of the Load Condition Indicator varies in loads.

Information in the table is for reference only.

2. The AC Input Indicator flashes in green in case of utility power abnormalities. The table only illustrates utility power disconnection as an example.

t1 : When the user turns on the NTN-5K and the AC input detects utility power, the inverter automatically enters bypass mode, allowing the utility power to directly feed to the loads and charging the battery simultaneously. In addition, when the battery voltage is below 26.5V, the inverter sets the SOLAR\_ON\_OFF signal (PIN4 of PAR1/PAR2) to a high level. If the system is configured with a solar charger, this signal can be used as an enable signal for the external charger.

t2 : When the battery voltage exceeds 28.5V, the NTN-5K sets the SOLAR\_ON\_OFF signal to a low level, which can be used as a disable signal for the external charger.

t3 : When the battery voltage reaches 28.8V, it is in a fully charged state. The charger enters float charge mode and the DC Input Indicator flashes in green.

t4 : When the NTN-5K detects a power outage or abnormal voltage/frequency from the utility, it enters inverter mode, disabling the charging function and converting battery energy into AC energy for the loads.

t5 : When the NTN-5K is in inverter mode, it converts the battery's DC energy into AC energy to supply the loads. As the battery voltage continues to decrease in this mode, when battery voltage drops below 26.5V, the inverter sets the SOLAR\_ON\_OFF signal to a high level, indicating to the external solar charger that it can charge the battery.

t6 : When the NTN-5K detects the reconnection of utility power or the return to normal voltage/frequency, it re-enters bypass mode, allowing utility power to feed the loads and charging the battery simultaneously. Similarly, if the battery voltage is below 26.5V, the NTN-5K sets the SOLAR\_ON\_OFF signal to a high level, enabling the external charger to charge the battery.

t7 : Same as t2

t8 : Same as t3

t9 : When the battery voltage drops below 22V, the DC Input Indicator lights in red and starts a warning sound, indicating low battery voltage alarm. If the battery continues to discharge and its voltage falls below 19V, indicating that the battery capacity is nearly drained, the NTN-5K will turn off itself for low DC voltage shutdown protection.

### 5.6.2 Explanation of Energy Saving Mode Control Logic

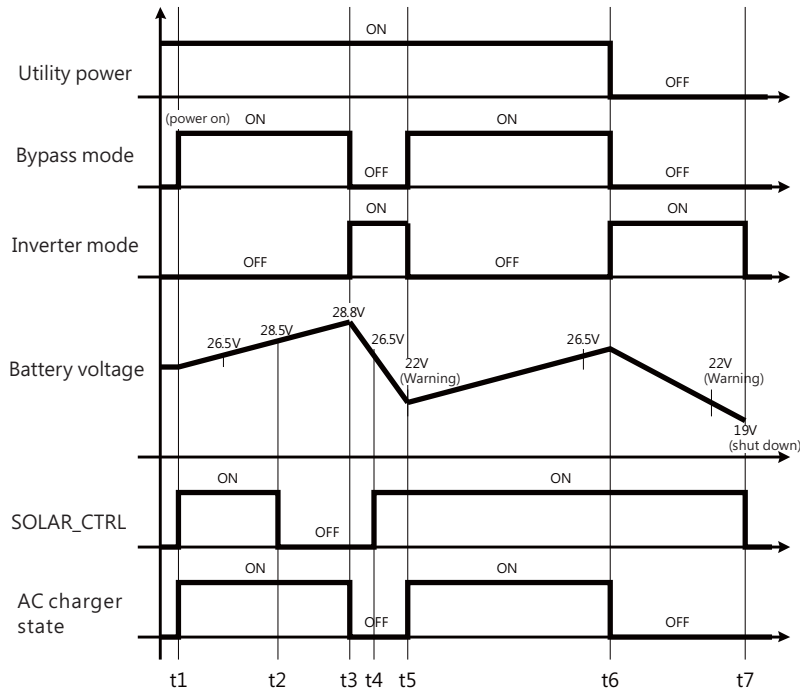

Figure 5.2 Diagram of Energy-saving Mode control logic

Table 5-2 Indicator table of Energy-saving Mode

	t1-t2	t2-t3	t3-t4	t4-t5	t5-t6	t6-t7	t7~
Status	●	●	●	●	●	●	●
DC input	☀	☀	●	●→●	☀	●→●→●	☀
Load signal	☀	☀	●	●	☀	●	○
AC input	●	●	●	●	●	○	○

NOTE:1. The color of the Load Condition Indicator varies in loads.

Information in the table is for reference only.

2. The AC Input Indicator flashes in green in case of utility power abnormalities. The table only illustrates utility power disconnection as an example.

- t1 : When the user turns on the NTN-5K and the AC input detects utility power, the NTN-5K automatically enters bypass mode. Unlike UPS mode, the Load Condition Indicator flashes in bypass mode, making it easier for users to identify the difference. Utility power directly is fed to the loads while simultaneously charging the battery. Additionally, when the battery voltage is below 26.5V, the inverter also sets the SOLAR\_ON\_OFF signal (PIN4 of PAR1/PAR2) to a high level. If the system is configured with a solar charger, this signal can be used as an enable signal for the external charger.
- t2 : When the battery voltage exceeds 28.5V, the NTN-5K sets the SOLAR\_ON\_OFF signal to a low level, which can be used as a disable signal for the external charger.
- t3 : When the battery voltage reaches 28.8V, indicating that the battery is fully charged, the NTN-5K switches to inverter mode, disabling the charging function and supplying AC energy to the loads from the battery.
- t4 : When the NTN-5K is in inverter mode, it converts the battery's DC energy into AC energy to supply the loads. As the battery voltage continues to decrease in this mode, when battery voltage drops below 26.5V, the inverter sets the SOLAR\_ON\_OFF signal to a high level, indicating to the external solar charger that it can charge the battery.
- t5 : When the battery voltage discharges below 22V (warning voltage), the inverter switches back to bypass mode if the utility power is connected normally. In bypass mode, utility power is fed to the loads while charging the battery simultaneously.
- t6 : When the NTN-5K detects a power outage or abnormal voltage/frequency from the utility, it enters inverter mode, disabling the charging function and converting battery energy into AC energy for the loads.
- t7 : When the battery voltage drops below 22V, the DC Input Indicator lights in red and starts a warning sound, indicating low battery voltage alarm. If the battery continues to discharge and its voltage falls below 19V, indicating that the battery capacity is nearly drained, the NTN-5K will turn off itself for low DC voltage shutdown protection.

### 5.6.3 Configuration Recommendation for an External Charger

Under UPS Mode or Energy-saving Mode, adding an MPPT solar charger at the battery end can extend the battery's usage time. Additionally, MEANWELL recommends that the charging on/off control of the external charger be controlled by the NTN-5K's SOLAR\_CTRL signal (PIN4 of PAR1/PAR2), which can further optimize the battery charging process.

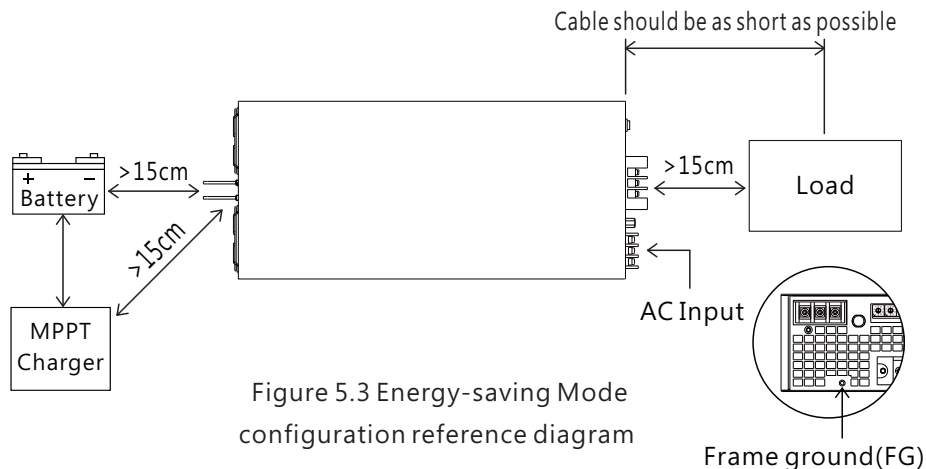

Figure 5.3 Energy-saving Mode configuration reference diagram

PAR1/PAR2	SOLAR_ON_OFF	Suggested operation of external charger
PIN4 to PIN2	5V	Continue charging
PIN4 to PIN2	0V	Stop charging

## 5.7 AC Charger

NTN-5K adopts both 2 and 3 stage charging curves for selection. 2 stage is for easy and fast charging. 3 stage goes into float mode after the battery is fully charged. Users can choose between 2 or 3 stage according to the demand. Charger settings can be selected and adjusted via communication protocol. For detailed information, please refer to commands related to charging such as CURVE\_CONFIG(0x00B4) in Chapter 6: Communication Protocol.

### 5.7.1 2 Stage Charging

In the initial stage of charging, the charger charges the battery with the maximum current. After a period of time (depending on the battery capacity), the charging current decreases gradually. When the charging current drops to 10% of the rated current, the DC Input Indicator lights up in green, indicating that the charging process is complete.

#### 2 stage charging curve

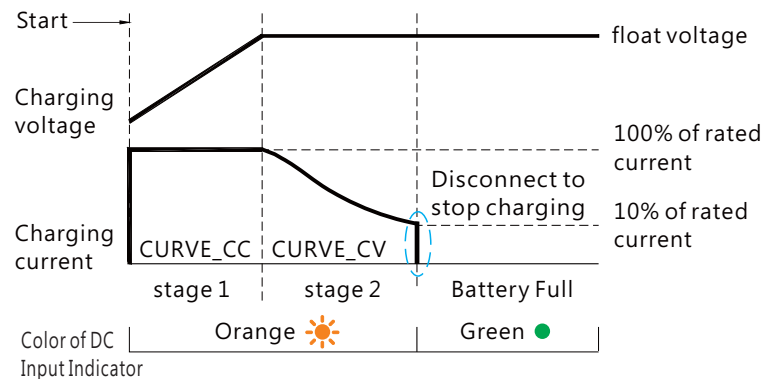

#### Explanation of 2 stage charging curve

- ① Stage 1 (Constant current): Maximum constant current is applied for fast charging, until the voltage of battery reaches to boost voltage
  - ② Stage 2 (Constant voltage): In this stage, charger applies a constant voltage on the battery. Charging current decreases gradually and then shuts down when charging current drops to 10% of rated current.
- \* Suitable for lead-acid batteries, such as flooded water type, Gel colloid type, AGM adsorption glass fiber and lithium batteries, such as lithium iron, lithium manganese, ternary lithium.

### 5.7.2 3 Stage Charging

In the initial stage of charging, the charger charges the battery with the maximum current. After a period of time (depending on the battery capacity), the charging current gradually decreases. When the charging current drops to 10% of the rated current. The DC Input Indiation flashes in green, indicating that the charging is complete and the charger remains float charging stage.

3 stage charging curve

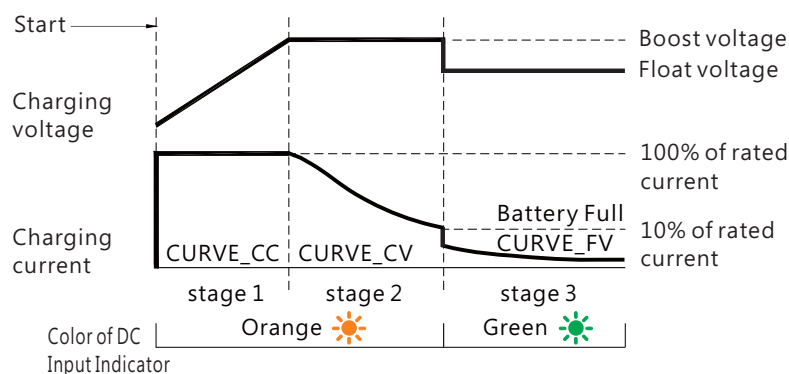

#### Explanation of 3 stage charging curve

- ① Stage 1 (Constant current): Maximum constant current is applied for fast charging, until the voltage of battery reaches to boost voltage.
- ② Stage 2 (Constant voltage): In this stage, charger applies a constant voltage on the battery. Charging current decreases gradually and then goes into the final stage when charging current drops to 10% of rated current.
- ③ Stage 3 (float charging): The charger is able to provide a float voltage after 2 stage charging in order to keep the battery fully charged at all times, especially suitable for lead-acid batteries.

\* Suitable for lead-acid batteries (flooded water type, Gel colloid type, AGM adsorption glass fiber).

### 5.7.3 Setting of Charging Curve

The factory default parameters are set to 'Default, programmable', and they are detailed in the tables below. If you wish to modify the charging parameters, you can do so through the communication protocol. For detailed information, please refer to commands related to charging, such as CURVE\_CONFIG (0x00B4), in Chapter 6: Communication Protocol.

24V model			
Description	CC(default)	V <sub>boost</sub>	V <sub>float</sub> (3 stage only)
Default, programmable	120A/1XX 135A/2XX	28.8V	27.6V
Pre-defined, gel battery		28.0V	27.2V
Pre-defined, flooded battery		28.4V	26.8V
Pre-defined, LiFeO4 battery		29.2V	28.0V

48V model			
Description	CC(default)	V <sub>boost</sub>	V <sub>float</sub> (3 stage only)
Default, programmable	60A/1XX 70A/2XX	57.6V	55.2V
Pre-defined, gel battery		56.0V	54.4V
Pre-defined, flooded battery		56.8V	53.6V
Pre-defined, LiFeO4 battery		58.4V	56.0V

380V model			
Description	CC(default)	V <sub>boost</sub>	V <sub>float</sub> (3 stage only)
Default, programmable	11.3A	400V	385V
Pre-defined, gel battery		390V	380V
Pre-defined, flooded battery		395V	372V
Pre-defined, LiFeO4 battery		400V max.	388V



### 5.7.4 Battery Temperature Compensation

- The battery temperature sensor (a NTC) that comes with the product can be connected to the battery for sensing temperature of the battery. The charge is able to work normally without the sensor.
- The temperature sensor which comes with the product can be connected to pin1 NTC(RTH-) and pin2 NTC(RTH+) in NTC connector. The wire length of the sensor can be adjusted according to different applications by linking the connector and sensor parts with wire length needed. Default setting is - 3mV/Cell/, °C compensated voltages are shown as below:

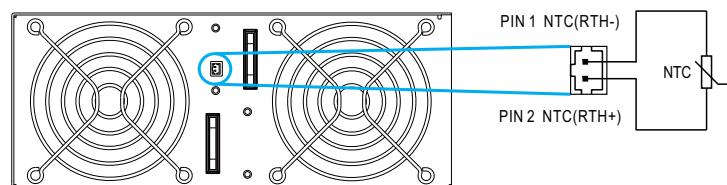

Model	Upper limit of voltage compensation	Lower limit of voltage compensation	Compensation range of temperature
24V	30V	20V	0 ~ 40°C
48V	60V	40V	
380V	400V	290V	

#### NOTE:

1. Different temperature compensation voltage can only be changed through the communication protocol.
2. The battery temperature compensation function only activates for 3 stage charging.

### 5.8 CMU2E, the GUI Controller For the NTN-5K

The CMU2E is a remote monitoring module designed to be used with the NTN-5K series. With its intuitive 7-inch TFT LCD touchscreen panel and physical buttons, users can easily perform on-site operations. The module's Ethernet port enables expanded connectivity, allowing for direct local-to-remote data access and real-time monitoring and control of the system. Equipped with four sets of programmable relays and five sets of isolated digital output signals, the CMU2E offers users flexibility in monitoring specific events or alarms. Additionally, the CMU2E supports data and event logging with date and time stamps, ensuring comprehensive record-keeping for analysis and troubleshooting. For detailed information, please refer to the CMU2E's User Manual.

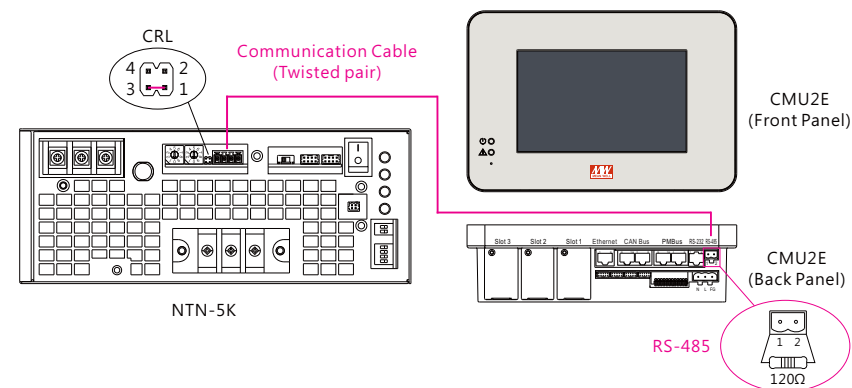



Example of user interface:



## 5.9 Factory Resetting

Users can follow the steps below to restore factory settings for commands: 0x00B0~0x00B7, 0x00B9~0x00BB, 0x0100~0x0103 and 0x00C4.

1. Set the rotary switch of AD2 to position 0.
2. Turn on the Main S.W. with the remote off. There should be no AC output in this condition.
3. Rotate the rotary switch from position 0 to position 7 and then back to position 0 again within 15 seconds.
4. If all of the LED indicators flash green three times, it means that the reset procedure has been done successfully.
5. The unit will load the factory default parameters after recycling the Main S.W.

AD2



## 6. Communication Protocol

### 6.1 Modbus Communication Interface

The device supports Modbus RTU with the master-slave principle. Users are able to read and write parameters of the device through the protocol, including remote ON/OFF, AC voltage/frequency setting, etc. During data transfer, please follow the principle of first sending the Hi byte and then the Lo byte except Error Check (CRC16 checksum).

Physical Layer setting as below:

Control	Setting
Baud Rate	115200
Data Bits	8
Stop Bit	1
Parity	None
Flow Control	None

#### 6.1.1 Communication Timing

- Min. request period (Controller to PSU/CHG): 50mSec °
- Max. response time (PSU/CHG to Controller): 12.5mSec °
- Min. packet margin time (Controller to PSU/CHG): 12.5mSec °

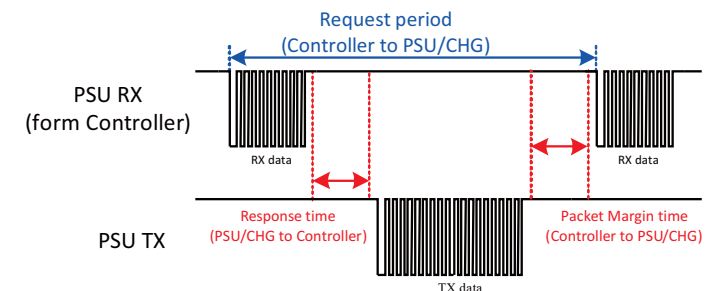

### 6.1.2 Modbus Frame Encapsulation

Modbus RTU consists of Additional Address, Function Code, Data and Error Check.

Additional Address	Function Code	Data	Error Check
1 byte	1 byte	N bytes	2 bytes

Additional address (1byte): Defines inverter's slave ID.

Function code (1byte): The function code is used to tell the slave what kind of action to perform.

Data (N bytes): For data exchange, contents and data length are dependent on different function codes.

Error Check (2bytes): Utilizes CRC-16.

### 6.1.3 Additional Address Definition

Additional address is the slave ID of the device. Each NTN-5K unit should have their unique and own device address to communicate over the Bus.

Slave ID	Description
0xC0 + XX	XX means device address (assigned by AD1 and AD2). For example: Address is set at 63, meaning Slave ID = 0xC0 + 0x3F = 0xFF
0x00	Broadcast

Note: XX means the address of the NTN-5K. Please refer to 4.7 Communication Address/ID Assignment for detailed.

### 6.1.4 Function Code Description

The main purpose of the function codes is to tell the slave what kind of action to perform. For example: Function code 03 will query the slave to read holding registers and respond with the master their contents.

Function Code		Description
Read Holding Register	0x03	Read Holding Register
Read Input Register	0x04	Read Input Register
Preset Single Register	0x06	Preset Single Register

### 6.1.5 Data Field and Command Lists

Data field provides additional information by the slave to complete the action specified by the function code (FC) in a request. The data field typically includes register addresses, count values, and written data. There are several forms according to the function codes.

FC = 03/04

Starting Address	Quantity of (Input) Registers
2 Bytes	2 Bytes

FC = 06

Register Address	Register Value
2 Bytes	2 Bytes

Command list:

Command Code	Command Name	Function code	# of data Bytes	Description
0x0050	READ_VIN	0x04	2	Single-phase input voltage (Bypass) (format: value, F=0.1)
0x0053	READ_IIN	0x04	2	Single-phase input current (Bypass) (format: value, F=0.1)
0x0056	READ_FREQ	0x04	2	Single-phase input frequency (Bypass) (format: value, F=0.01)
0x0062	READ_TEMPERATURE_1	0x04	2	Internal temperature read value (format: value, F=0.1)
0x0070	READ_FAN_SPEED_1	0x04	2	Fan 1 speed read value (format: value, F=1)
0x0071	READ_FAN_SPEED_2	0x04	2	Fan 2 speed read value (format: value, F=1)
0x0080	MFR_ID_B0B5	0x03	6	Manufacture's name
0x0083	MFR_ID_B6B11	0x03	6	Manufacture's name
0x0086	MFR_MODEL_B0B5	0x03	6	Manufacture model name
0x0089	MFR_MODEL_B6B11	0x03	6	Manufacture model name
0x008C	MFR_REVISION_B0B5	0x03	6	Firmware version
0x008F	MFR_LOCATION_B0B2	0x03	4	Manufacture location
0x0091	MFR_DATE_B0B5	0x03	6	Manufacture date
0x0094	MFR_SERIAL_B0B5	0x03	6	Manufacture serial number
0x0097	MFR_SERIAL_B6B11	0x03	6	Manufacture serial number
0x00B0	CURVE_CC*	0x03, 0x06	2	Constant current setting of charge curve (format: value, F=0.01)

Command Code	Command Name	Function code	# of data Bytes	Description
0x00B1	CURVE_CV*	0x03, 0x06	2	Constant current setting of charge curve (format: value, F=0.01)
0x00B2	CURVE_FV*	0x03, 0x06	2	Float voltage setting of charge curve (format: value, F=0.01)
0x00B3	CURVE_TC*	0x03, 0x06	2	Taper current setting of charge curve (format: value, F=0.01)
0x00B4	CURVE_CONFIG	0x03, 0x06	2	Configuration setting of charge curve
0x00B5	CURVE_CC_TIMEOUT	0x03, 0x06	2	CC charge timeout setting of charging curve (format: value, F=1)
0x00B6	CURVE_CV_TIMEOUT	0x03, 0x06	2	CV charge timeout setting of charging curve (format: value, F=1)
0x00B7	CURVE_FV_TIMEOUT	0x03, 0x06	2	FV charge timeout setting of charging curve (format: value, F=1)
0x00B8	CHG_STATUS	0x03	2	Charge status reporting
0x00B9	BAT_ALM_VOLT*	0x03, 0x06	2	Battery low voltage alarm threshold (format: value, F=0.01)
0x00BA	BAT_SHDN_VOLT*	0x03, 0x06	2	Battery low voltage shutdown threshold (format: value, F=0.01)
0x00BB	BAT_RCHG_VOLT*	0x03, 0x06	2	Battery recharge voltage threshold (format: value, F=0.01)
0x00C0	SCALING_FACTOR	0x03	6	Scaling ratio
0x00C4	SYSTEM_CONFIG	0x03, 0x06	2	System configuration
0x00CF	SETTING_UBLOCK	0x06	2	Setting Unlock (NOTE:1)
0x0100	INV_OPERATION	0x03, 0x06	2	Operation configuration
0x0101	INV_CONFIG	0x03, 0x06	2	UPS or Energy-saving mode configuration

Command Code	Command Name	Function code	# of data Bytes	Description
0x0102	Output ACV_Set	0x03, 0x06	2	Output AC Voltage Setting 110/220series: 1: 100/200 2: 110/220 3: 115/230 4: 120/240 0: disable(by DIP SW) (NOTE:1)
0x0103	Output ACF_Set	0x03, 0x06	2	Output AC Frequency Setting 1: 50Hz 2: 60Hz 0: disable(by DIP SW) (NOTE:1)
0x0105	READ_AC_FOUT	0x04	2	Output AC Frequency read value (format: value, F=0.01)
0x0108	READ_AC_VOUT	0x04	2	Output AC Voltage read value (format: value, F=0.1)
0x010B	READ_OP_LD_PCNT	0x04	2	O/P load percent read value, 0~100%
0x010E	READ_OP_WATT_HI	0x04	2	O/P wattage read value (High) (format: value, F=0.1)
0x010F	READ_OP_WATT_LO	0x04	2	O/P wattage read value (Low) (format: value, F=0.1)
0x0114	READ_OP_VA_HI	0x04	2	O/P apparent power read value (High) (format: value, F=0.1)
0x0115	READ_OP_VA_LO	0x04	2	O/P apparent power read value (Low) (format: value, F=0.1)
0x011A	READ_VBAT	0x04	2	Battery voltage read value (format: value, F=0.01)
0x011B	READ_CHG_CURR	0x04	2	Battery current read value (format: value, F=0.01)
0x011C	BAT_CAPACITY	0x04	2	Battery capacity percent read value, 0~100%

Command Code	Command Name	Function code	# of data Bytes	Description
0x011D	INV_STATUS	0x04	2	Inverter operation status reading
0x011E	INV_FAULT	0x04	2	Inverter abnormal status reading
0x011F	READ_BP_WATT_HI	0x04	2	Bypass wattage read value (High) (format: value, F=0.1)
0x0120	READ_BP_WATT_LO	0x04	2	Bypass wattage read value (Low) (format: value, F=0.1)
0x0125	READ_BP_VA_HI	0x04	2	Bypass apparent power read value (High) (format: value, F=0.1)
0x0126	READ_BP_VA_LO	0x04	2	Bypass apparent power read value (Low) (format: value, F=0.1)
0x012B	READ_AC_IOUT	0x04	2	AC output current read value (format: value, F=0.1)

**NOTE:**

1. Before setting commands of Output ACV\_Set and Output ACF\_Set, please utilize the SETTING\_UBLOCK command to unlock. Refer to section 6.2.2 for detailed instructions.
2. Setting commands with \* at the end support the EEP\_OFF and EEP\_CONFIG functions. For detailed information on how to enable them, please refer to SYSTEM\_CONFIG (0x00C4).

**Data conversion:**

The conversion of setting and reading values is defined as following:

Actual value = Communication reading value × Factor (F value).

Among them, Factor needs to refer to the definition of SCALING\_FACTOR in each model list.

EX: AC output frequency read value = READ\_FREQ × Factor.

If the Factor of READ\_FREQ of a certain model is 0.01, the communication reading value is 0x1770 (hexadecimal) → 6000 (decimal), then VDC\_real = 6000 × 0.01 = 60Hz.

◎MFR\_ID\_B0B5(0x0080) is the first 6 codes of the manufacturer's name (ASCII); MFR\_ID\_B6B11(0x0083) is the last 6 codes of the manufacturer's name (ASCII)

EX: manufacturer's name is MEANWELL → MFR\_ID\_B0B5 is MEANWE ; MFR\_ID\_B6B11 is LL

MFR_ID_B0B5					
Byte 0	Byte 1	Byte 2	Byte 3	Byte 4	Byte 5
0x4D	0x45	0x41	0x4E	0x57	0x45

MFR_ID_B6B11					
Byte 0	Byte 1	Byte 2	Byte 3	Byte 4	Byte 5
0x4C	0x4C	0x20	0x20	0x20	0x20

◎MFR\_MODEL\_B0B5 (0x0086) is the first 6 codes of the manufacturer s model name ' (ASCII); MFR\_MODEL\_B6B11 (0x0089) is the last 6 codes of the manufacturer s model ' name (ASCII)

EX: Model name is NTN-5K-224 → MFR\_MODEL\_B0B5 is NTN-5K; MFR\_MODEL\_B6B11 is -224

MFR_MODEL_B0B5					
Byte 0	Byte 1	Byte 2	Byte 3	Byte 4	Byte 5
0x4E	0x54	0x4E	0x2D	0x35	0x4B

MFR_MODEL_B6B11					
Byte 6	Byte 7	Byte 8	Byte 9	Byte 10	Byte 11
0x2D	0x32	0x32	0x34	0x20	0x20

◎MFR\_REVISION\_B0B5 (0x008C) is the firmware revision. A range of 0x00 hexadecimal (R00.0)~0xFE (R25.4) represents the firmware version of an MCU; 0xFF represents no MCU existed.

EX: The inverter has three MCUs, the firmware version of the MCU number 1 is version R01.3 (0x0D), the MCU number 2 is version R01.2 (0x0C) and the MCU number 3 is version R01.1 (0x0B).

Byte 0	Byte 1	Byte 2	Byte 3	Byte 4	Byte 5
0x0D	0x0C	0x0B	0xFF	0xFF	0xFF

◎MFR\_DATE\_B0B5 (0x0091) is manufacture date (ASCII)

EX: MFR\_DATE\_B0B5 is 180101, meaning 2018/01/01

Byte 0	Byte 1	Byte 2	Byte 3	Byte 4	Byte 5
0x31	0x38	0x30	0x31	0x30	0x31

◎MFR\_SERIAL\_B0B5 (0x0094) and MFR\_SERIAL\_B6B11 (0x0097) are defined as manufacture date and manufacture serial number (ASCII)

EX: The first unit manufactured on 2018/01/01 → MFR\_SERIAL\_B0B5: 180101 ; MFR\_SERIAL\_B6B11: 000001

MFR_SERIAL_B0B5					
Byte 0	Byte 1	Byte 2	Byte 3	Byte 4	Byte 5
0x31	0x38	0x30	0x31	0x30	0x31

MFR_SERIAL_B6B11					
Byte 6	Byte 7	Byte 8	Byte 9	Byte 10	Byte 11
0x30	0x30	0x30	0x30	0x30	0x31

©CURVE\_CONFIG(0x00B4) :

	Bit7	Bit6	Bit5	Bit4	Bit3	Bit2	Bit1	Bit0
High byte	-	-	-	-	-	FVTOE	CVTOE	CCTOE
Low byte	-	STGS	-	-	TCS		CUVS	

Low byte:

Bit 0:1 CUVS: Charge Curve Selection

00 = Customized charge Curve (default)

01 = Gel Battery

10 = Flooded Battery

11 = AGM Battery

Bit 2:3 TCS: Temperature Compensation Setting

00 = disable

01 = -3 mV/°C/cell (default) 10 = -4 mV/°C/cell

11 = -5 mV/°C/cell

Bit 6:STGS: 2/3 Stage Charge Setting

0 = 3 stage charge (default, CURVE\_CV and CURVE\_FV)

1 = 2 stage charge (only CURVE\_CV)

High byte:

Bit 0 CCTOE: Constant Current Stage Timeout Indication Enable

0 = disable (default)

1 = enabled

Bit 1 CVTOE: Constant Voltage Stage Timeout Indication Enable

0 = disable (default)

1 = enabled

Bit 2 FVTOE: Float Voltage Stage Timeout Indication Enable

0 = disable (default)

1 = enabled

Note: Unsupported settings displays with "0"

©CHG\_STATUS(0x00B8) :

	Bit7	Bit6	Bit5	Bit4	Bit3	Bit2	Bit1	Bit0
High byte	FVTOF	CVTOF	CCTOF	-	-	NTCER	-	-
Low byte	-	-	-	-	FVM	CVM	CCM	FULLM

Low byte:

Bit 0 FULLM: Fully Charged Mode Status

0 = NOT fully charged

1 = fully charged

Bit 1 CCM: Constant Current Mode Status

0 = the charger NOT in constant current mode

1 = the charger in constant current mode

Bit 2 CVM: Constant Voltage Mode Status

0 = the charger NOT in constant voltage mode

1 = the charger in constant voltage mode

Bit 3 FVM: Float Mode Status

0 = the charger NOT in float mode

1 = the charger in float mode

High byte:

Bit 2 NTCER: Temperature Compensation Status

0 = NO short-circuit in the circuitry of temperature compensation

1 = the circuitry of temperature compensation has short-circuited

Bit 5 CCTOF: Time Out Flag of Constant Current Mode

0 = NO time out in constant current mode

1 = constant current mode timed out

Bit 6 CVTOF: Time Out Flag of Constant Voltage Mode

0 = NO time out in constant voltage mode

1 = constant voltage mode timed out

Bit 7 FTTOF: Time Out Flag of Float Mode

0 = NO time out in float mode

1 = float mode timed out

Note: Unsupported settings displays with "0"

©SCALING\_FACTOR(0x00C0):

Byte5	Bit7	Bit6	Bit5	Bit4	Bit3	Bit2	Bit1	Bit0
Definition	Reserved				Reserved			
Supported?	NO				NO			
Byte4	Bit7	Bit6	Bit5	Bit4	Bit3	Bit2	Bit1	Bit0
Definition	Reserved				Frequency Factor			
Supported?	NO				YES			
Byte3	Bit7	Bit6	Bit5	Bit4	Bit3	Bit2	Bit1	Bit0
Definition	Watt Factor				IIN Factor / IAC Factor			
Supported?	YES				YES			
Byte2	Bit7	Bit6	Bit5	Bit4	Bit3	Bit2	Bit1	Bit0
Definition	CURVE_TIMEOUT Factor				TEMPERATURE_1 Factor			
Supported?	YES				YES			
Byte1	Bit7	Bit6	Bit5	Bit4	Bit3	Bit2	Bit1	Bit0
Definition	FAN_SPEED Factor				VIN Factor / VAC Factor			
Supported?	YES				YES			
Byte0	Bit7	Bit6	Bit5	Bit4	Bit3	Bit2	Bit1	Bit0
Definition	IOUT Factor / IDC Factor				VOUT Factor / VDC Factor			
Supported?	YES				YES			

Bit 0:3 VOUT Factor/VDC Factor : The factor of output voltage/DC voltage

0x0=Output voltage relevant commands not supported

0x1~0x3=Not in use, reserved (default is 0)

0x4=0.001

0x5=0.01

0x6=0.1

0x7=1.0

0x8=10

0x9=100

0xA~0xF= Reserved

Bit 4:7 IOUT Factor/IDC Factor : The Factor of output current/ DC current

0x0=Output current relevant commands not supported

0x1~0x3=Not in use, reserved (default is 0)

0x4=0.001

0x5=0.01

0x6=0.1

0x7=1.0

0x8=10

0x9=100

0xA~0xF= Reserved

byte1:

Bit 0:3 VIN Factor/VAC Factor : The Factor of input voltage/ AC voltage Factor

0x0=AC input relevant commands not supported

0x1~0x3=Not in use, reserved (default is 0)

0x4=0.001

0x5=0.01

0x6=0.1

0x7=1.0

0x8=10

0x9=100

0xA~0xF= Reserved

Bit 4:7 FAN\_SPEED Factor : The Factor of fan speed

0x0=Fan speed relevant commands not supported

0x1~0x3=Not in use, reserved (default is 0)

0x4=0.001

0x5=0.01

0x6=0.1

0x7=1.0

0x8=10

0x9=100

0xA~0xF= Reserved

byte2:  
Bit 0:3 TEMPERATURE\_1 Factor : The Factor of internal ambient temperature  
0x0=internal ambient temperature relevant commands not supported  
0x1~0x3=Not in use, reserved (default is 0)  
0x4=0.001  
0x5=0.01  
0x6=0.1  
0x7=1.0  
0x8=10  
0x9=100  
0xA~0xF= Reserved

Bit 4:7 CURVE\_TIMEOUT Factor : The Factor of CC/CV/Float timeout  
0x0=CURVE\_TIMEOUT relevant commands not supported  
0x1~0x3=Not in use, reserved (default is 0)  
0x4=0.001  
0x5=0.01  
0x6=0.1  
0x7=1.0  
0x8=10  
0x9=100  
0xA~0xF= Reserved

byte3:  
Bit 0:3 IIN Factor/IAC Factor : The Factor of input current/AC current  
0x0=AC input current relevant commands not supported  
0x1~0x3=Not in use, reserved (default is 0)  
0x4=0.001  
0x5=0.01  
0x6=0.1  
0x7=1.0  
0x8=10  
0x9=100  
0xA~0xF= Reserved

Bit 4:7 Watt Factor : The Factor of output AC wattage (Power/Reactive/VA)  
0x0=AC wattage relevant commands not supported  
0x1~0x3=Not in use, reserved (default is 0)  
0x4=0.001  
0x5=0.01  
0x6=0.1  
0x7=1.0  
0x8=10  
0x9=100  
0xA~0xF= Reserved

byte4:  
Bit 0:3 Frequency Factor : The Factor of Frequency  
0x0=Frequency relevant commands not supported  
0x1~0x3=Not in use, reserved (default is 0)  
0x4=0.001  
0x5=0.01  
0x6=0.1  
0x7=1.0  
0x8=10  
0x9=100  
0xA~0xF= Reserved



◎SYSTEM\_CONFIG (0x00C4) :

	Bit7	Bit6	Bit5	Bit4	Bit3	Bit2	Bit1	Bit0
High byte	-	-	-	-	-	EEP_OFF	EEP_CONFIG	
Low byte	-	-	-	-	-	-	-	-

High Byte:

Bit 0:1 EEP\_CONFIG : EEPROM Configuration

00: Immediate. Changes to parameters are written to EEPROM immediately (factory default)

01: 1 minute delay. Write changes to EEPROM if all parameters remain unchanged for 1 minute

10: 10 minute delay. Write changes to EEPROM if all parameters remain unchanged for 10 minutes

11: Reserved

Bit 2 EEP\_OFF : EEPROM storage function ON/OFF

0: Enable. Parameters to be saved into EEPROM (factory default)

1: Disable. Parameters NOT to be saved into EEPROM

◎INV\_OPERATION(0x0100) :

	Bit7	Bit6	Bit5	Bit4	Bit3	Bit2	Bit1	Bit0
High byte	-	-	-	-	-	-	-	-
Low byte	-	-	-	-	-	CHG_EN	OP_EN	OP_CTRL

Low byte:

Bit 0:OP\_CTRL : AC output control

0= Turn OFF AC output

1= Turn ON AC output (Default)

Bit 1:OP\_EN: Enablement of AC output control

0= The control of AC output by the 'OP\_CTRL' bit is disabled (Default)

1= The control of AC output by the 'OP\_CTRL' bit is enabled

Bit 2:CHG\_EN : AC charger control

0= Turn OFF the AC charger when in AC bypass mode

1= Turn ON the AC charger when in AC bypass mode(Default)

Note: Unsupported settings displays with "0"

◎INV\_CONFIG(0x0101) :

	Bit7	Bit6	Bit5	Bit4	Bit3	Bit2	Bit1	Bit0
High byte	-	-	-	-	-	-	-	-
Low byte	-	-	-	-	-	-	INV_Prio	

Low byte:

Bit 0:1 INV\_Prio: Operation mode selection

b00= UPS Mode (Default)

b01= Energy-saving Mode

b10= Reserved

b11= Reserved

Note: Unsupported settings displays with "0"

◎INV\_STATUS(0x011D) :

	Bit7	Bit6	Bit5	Bit4	Bit3	Bit2	Bit1	Bit0
High byte	-	-	-	-	-	-	INV_PHASE	
Low byte	-	Bat_Low_ALM	SAVING	SOLAR_EN	CHG_ON	UTI_OK	BYP	INV

Low byte:

Bit 0:INV: Inverter mode

0= The AC output is NOT provided from the inverter

1= The AC output is provided from the inverter

Bit 1:BYP: Bypass mode

0= The AC output is NOT provided from the external AC source (Utility)

1= The AC output is provided from the external AC source (Utility)

Bit 2:UTI\_OK: Utility power exist

0= Utility power failure

1= Utility power normal

Bit 3:CHG\_ON: Charger status

0= Charger OFF

1= Charger ON

Bit 4:SOLAR\_ON: Solar charger control ON

0= Enable signal for the external solar charger

1= Disable signal for the external solar charger

Bit 5:SAVING: Saving Mode  
 0 = The inverter is NOT in Saving Mode  
 1 = The inverter is in Saving Mode

Bit 6: Bat\_Low\_ALM: Battery low alarm  
 0 = Battery low alarm is NOT triggered  
 1 = Battery low alarm is triggered

High byte:

Bit 0:1 INV\_PHASE: Inverter output phase setting  
 b00 = 0°(Default)  
 b10 = 120° (For three-phase 4-wire configuration only)  
 b11 = -120° (For three-phase 4-wire configuration only)

Unsupported settings displays with "0"

©INV\_FAULT(0x011E) :

	Bit7	Bit6	Bit5	Bit4	Bit3	Bit2	Bit1	Bit0
High byte	Reserved	Reserved	Reserved	INV_Fault	Bat_OVP	Bat_UVP	FAN_FAIL	SHDN
Low byte	EEP_Err	SCP	INV_OVP	INV_UVP	OTP	OLP_150	OLP_115	OLP_100

Low byte:

Bit 0:OLP\_100 : OLP 100 ~ 115 %  
 0 = No  
 1 = Yes

Bit 1:OLP\_115 : OLP 115 ~ 150 %  
 0 = No  
 1 = Yes

Bit 2:OLP\_150 : OLP 150% ~  
 0 = No  
 1 = Yes

Bit 3:OTP : OTP  
 0 = No  
 1 = Yes

Bit 4: INV\_UVP: Inverter UVP  
 0 = No  
 1 = Yes

Bit 5: INV\_OVP: Inverter OVP  
 0 = No  
 1 = Yes

Bit 6: SCP: Short circuit protection  
 0 = No  
 1 = Yes

Bit 7: EEP\_Err: EEPROM error code  
 0 = No  
 1 = Yes

High byte

Bit 0: SHDN: System Shutdown  
 0 = No  
 1 = Yes

Bit 1: FAN\_FAIL: Fan lock  
 0 = No  
 1 = Yes

Bit 2: Bat\_UVP: Battery under-voltage shutdown  
 0 = No  
 1 = Yes

Bit 3: Bat\_OVP: Battery over-voltage shutdown  
 0 = No  
 1 = Yes

Bit 4: INV\_Fault: Inverter Fault  
 0 = No  
 1 = Yes

### 6.1.6 Modbus Communication Examples

The following provides examples of request and response for each function code of the Modbus RTU.

#### 6.1.6.1 Function Code

##### 6.1.6.1.1 Read Holding Registers (FC = 03)

The request message specifies the starting register and quantity of registers to be read. For example: the master requests the content of analog output holding registers 0x008C-0 008E (MFR\_REVISION\_B0B5) from slave 0

Request:

0xC0	0x03	0x008C	0x0003	0xD4F1
------	------	--------	--------	--------

0xC0: Slave ID 0

0x03: Function code 3 (Read Analog Output Holding R Registers)

0x008C: The Data Address of the first register requested.

0x0003: The total number of registers requested (Read 3 registers from 0x008C to 0x008E)

0xD4F1: CRC16 Error Check. Please be aware that CRC sending the Lo byte first.

Response:

0xC0	0x03	0x06	0x0A0A0AFFFFFF	0xAD38
------	------	------	----------------	--------

0xC0: Slave ID 0

0x03: Function code 3 (Read Analog Output Holding R Registers)

0x06: The number of data bytes to follow (6 bytes).

0x0A0A0AFFFFFF, meaning that the firmware version of the MCU number 1~number 3 is R01.0

0xAD38: CRC16 Error Check. Please be aware that CRC sending the Lo byte first.

##### 6.1.6.1.2 Read Input Register (FC=04)

The request message specifies the starting register and quantity of registers to be read. For example: The master requests the content of analog input register 0x0056 (READ\_FREQ) from slave 0.

Request:

0xC0	0x04	0x0056	0x0001	0xC10B
------	------	--------	--------	--------

0xC0: Slave ID 0

0x04: Function code 4 (Read Analog Input Register)

0x0056: The Data Address of the first register requested

0x0001: The total number of registers requested (read only 1 registers from 0x0056)

0xC10B: CRC16 Error Check. Please be aware that CRC sending the Lo byte first.

Response:

0xC0	0x04	02	0x1770	0x8AF5
------	------	----	--------	--------

0xC0: Slave ID 0

0x04: Function code 4 (Read Analog Input Register)

0x02: The number of data bytes to follow (2 bytes)

0x1770: The contents of register: 0x0056 (READ\_FREQ). 0x 1770 = 6000 = 60.00Hz

0x8AF5: CRC16 Error Check. Please be aware that CRC sending the Lo byte first

##### 6.1.6.1.3 Write Single Register (FC=06)

The request message specifies the register reference to be written.

For example: The master writes 40V to analog output holding register of 0x00B9 (BAT\_ALM\_VOLT) for slave 0

Request:

0xC0	0x06	0x00B9	0x0FA0	0x4D76
------	------	--------	--------	--------

0xC0: Slave ID 0

0x06: Function code 6 (Preset Single Register)

0x00B9: The Data Address of the register

0x0FA0: The value to write. 0x0FA0 → 4000 = 40V

0x4D76: CRC16 Error Check. Please be aware that CRC sending the Lo byte first

Response:

The normal response is an echo of the query, returned after the register contents have been written.

##### 6.1.6.2 Settings of Output ACV\_Set (0x0102) and Output ACF\_Set (0x0103)

To secure settings of the AC output voltage and frequency, a different writing method is required for Output ACV\_Set(0x0102) and Output ACF\_Set(0x0103) commands, that is these commands must first be unlocked by SETTING\_UBLOCK(0x00CF) before any changes can be made.

- Output ACV\_Set(0x0102)

C0 06 00 CF 4D 57 DD 8A	Unlock password is 0x4D57(MW)
C0 06 01 02 00 00 39 27	AC output voltage setting is controlled by SW1

NOTE: After completing the settings, please reboot the inverter to apply the new changes

### 6.1.6.3 Remote-on/off via Communication

If ON/OFF control of the AC output via communication is required, first set Bit 1 (OP\_EN) of INV\_OPERATION(0x0100) to "1". Then, Bit 0 (OP\_CTRL) can be utilized to manage the state of the inverter's AC output. Below is an example of how to utilize the protocol to turn off the AC output.

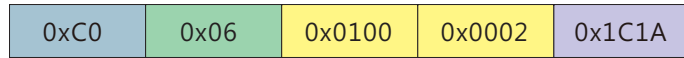

### 6.1.6.4 Practical Operation

The following steps will describe how to configure the NTN-5K-148 or 248 to Energy-saving Mode and adjust its charge curve for 2-stage charging, with a constant current (CC) of 50A and a constant voltage (CV) of 56V.

⊙Set the address of the inverter to "0".

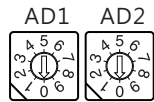

⊙Connect the D+ /D- pins of the master to the corresponding D+(PIN2) and D-(PIN3) pins of the COMM connector on the inverter. It is recommended to establish a common ground for the communication system to increase its communication reliability by using GND-AUX (PIN1) of COMM.

⊙Recommended settings are as follows

Control	Setting
Baud Rate	115200
Data Bits	8
Stop Bit	1
Parity	None
Flow Control	None

- ⊙Adding a 120 termination resistor to both the controller and inverter end can increase communication stability
- ⊙If the unit is a terminal, it is recommended to connect a termination resistor, that is short circuit PIN1 and PIN3 of CRL.

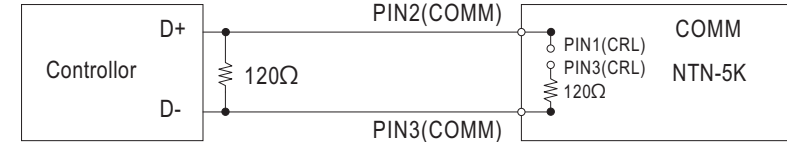

⊙Configure communication settings after power on. First, set the NTN-5K to 2-stage charging.

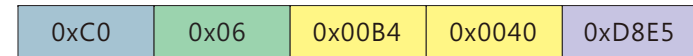

- 0xC0: Slave ID0
- 0x06: Function code 6 (Write Single Register)
- 0x00B4: CURVE\_CONFIG register
- 0x0040: Set to 2 stage charging. Please refer to definition of CURVE\_CONFIG for detailed information
- 0x1C1A: CRC16 Error Check

⊙Set c constant current to 50A

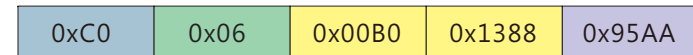

- 0xC0: Slave ID0
  - 0x06: Function code 6 (Write Single Register)
  - 0x00B0: CURVE\_CC register
  - 0x1388: 50A → 5000 → 0x1388
  - 0x95AA: CRC16 Error Check
- NOTE: Conversion factor for CURVE\_CC is  $0.01 \cdot \text{so} \frac{50A}{F=0.01} = 5000$

©Set constant voltage to 56V

0xC0	0x06	0x00B1	0x15E0	0xC624
------	------	--------	--------	--------

0xC0: Slave ID0

0x06: Function code 6 (Write Single Register)

0x00B1: CURVE\_CV register

0x15E0: 56V → 5600 → 0x15E0

0xC624: CRC16 Error Check

NOTE: Conversion factor for CURVE\_CV is  $0.01 \cdot \text{so } \frac{56V}{F=0.01} = 5600$

©Set operation mode to Energy-saving Mode

0xC0	0x06	0x0101	0x0001	0x5DDE
------	------	--------	--------	--------

0xC0: Slave ID0

0x06: Function code 6 (Write Single Register)

0x0101: INV\_CONFIG register

0x0001: Set to Energy-saving Mode. Please refer to definition of CURVE\_CONFIG for detailed information

0x5DDE: CRC16 Error Check

©Finally, check whether RC\_1(PIN3) and +5-AUX 2(PIN1) pins of the RAP1 or PAR 2 connector are short-circuited if there is no AC output voltage

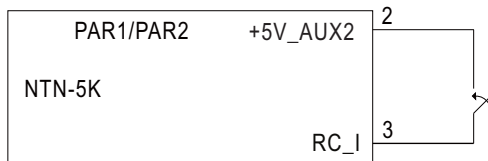

## 6.2 CAN Bus Communication Interface

- Physical layer specification  
This protocol follows CAN ISO-11898 with Baud rate of 250Kbps.

- Data Frame  
This protocol uses Extended CAN 29-bit identifier frame format or CAN 2.0B.

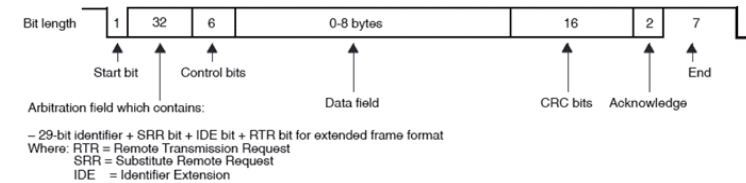

- Communication Timing  
Min. request period (Controller to NTN-5K): 50mSec ◦  
Max. response time (NTN-5K to Controller): 12.5mSec ◦  
Min. packet margin time (Controller to NTN-5K): 12.5mSec ◦

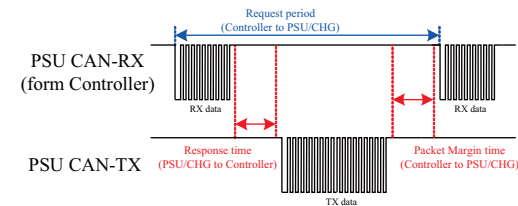

- Data Field Format  
Controller to NTN  
Write:

Data filed bytes

0	1	2	3
COMD. low byte	COMD. high byte	Data low byte	Data high byte

Data filed bytes

0	1
COMD. low byte	COMD. high byte

NTN to Controller

Response:

Data filed bytes

0	1	2	...	7
COMD. low byte	COMD. high byte	Data low 1	.....	Data high 6

Note: NTN-5K will not send data back when write parameters, such as Output ACV\_Set

### 6.2.1 Message ID Definition

Message ID	Description
0x000C04XX	NTN-5K to Controller Message ID
0x000C05XX	Controller to NTN-5K Message ID
0x000C05FF	Controller broadcasts to NTN-5K Message ID

Note: XX means the address of the NTN-5K. Please refer to 4.7 Communication Address/ID Assignment for detailed.

### 6.2.2 CAN Bus Command List

Command Code	Command Name	Transaction Type	# of data Bytes	Description
0x0050	READ_VIN	R	2	Single-phase input voltage (Bypass) (format: value, F=0.1)
0x0053	READ_IIN	R	2	Single-phase input current (Bypass) (format: value, F=0.1)
0x0056	READ_FREQ	R	2	Single-phase input frequency (Bypass) (format: value, F=0.01)
0x0062	READ_TEMPERATURE_1	R	2	Internal temperature read value (format: value, F=0.1)
0x0070	READ_FAN_SPEED_1	R	2	Fan 1 speed read value (format: value, F=1)
0x0071	READ_FAN_SPEED_2	R	2	Fan 2 speed read value (format: value, F=1)
0x0080	MFR_ID_B0B5	R	6	Manufacture's name
0x0081	MFR_ID_B6B11	R	6	Manufacture's name
0x0082	MFR_MODEL_B0B5	R	6	Manufacture model name
0x0083	MFR_MODEL_B6B11	R	6	Manufacture model name
0x0084	MFR_REVISION_B0B5	R	6	Firmware version
0x0085	MFR_LOCATION_B0B2	R/W	3	Manufacture location
0x0086	MFR_DATE_B0B5	R/W	6	Manufacture date

Command Code	Command Name	Transaction Type	# of data Bytes	Description
0x0087	MFR_SERIAL_B0B5	R/W	6	Manufacture serial number
0x0088	MFR_SERIAL_B6B11	R/W	6	Manufacture serial number
0x00B0	CURVE_CC*	R/W	2	Constant current setting of charge curve (format: value, F=0.01)
0x00B1	CURVE_CV*	R/W	2	Constant voltage setting of charge curve (format: value, F=0.01)
0x00B2	CURVE_FV*	R/W	2	Float voltage setting of charge curve (format: value, F=0.01)
0x00B3	CURVE_TC*	R/W	2	Taper current setting of charge curve (format: value, F=0.01)
0x00B4	CURVE_CONFIG	R/W	2	Configuration setting of charge curve
0x00B5	CURVE_CC_TIMEOUT	R/W	2	CC charge timeout setting of charging curve (format: value, F=1)
0x00B6	CURVE_CV_TIMEOUT	R/W	2	CV charge timeout setting of charging curve (format: value, F=1)
0x00B7	CURVE_FV_TIMEOUT	R/W	2	FV charge timeout setting of charging curve (format: value, F=1)
0x00B8	CHG_STATUS	R	2	Charge status reporting
0x00B9	BAT_ALM_VOLT*	R/W	2	Battery low voltage alarm threshold (format: value, F=0.01)
0x00BA	BAT_SHDN_VOLT*	R/W	2	Battery low voltage shutdown threshold (format: value, F=0.01)
0x00BB	BAT_RCHG_VOLT*	R/W	2	Battery recharge voltage threshold (format: value, F=0.01)
0x00C0	SCALING_FACTOR	R	6	Scaling ratio
0x00C2	SYSTEM_CONFIG	R/W	2	System configuration
0x00CF	SETTING_UBLOCK	W	2	Setting Unlock (NOTE:1)

Command Code	Command Name	Transaction Type	# of data Bytes	Description
0x0100	INV_OPERATION	R/W	2	Operation configuration
0x0101	INV_CONFIG	R/W	2	UPS or Energy-saving mode configuration
0x0102	Output ACV_Set		2	Output AC Voltage Setting 110/220series: 1: 100/200 2: 110/220 3: 115/230 4: 120/240 0: disable(by DIP SW)
0x0103	Output ACF_Set	R/W	2	Output AC Frequency Setting 1: 50Hz 2: 60Hz 0: disable(by DIP SW)
0x0105	READ_AC_FOUT	R	2	Output AC Frequency read value (format: value, F=0.01)
0x0108	READ_AC_VOUT	R	2	Output AC Voltage read value (format: value, F=0.1)
0x010B	READ_OP_LD_PCNT	R	2	O/P load percent read value, 0~100%
0x010E	READ_OP_WATT_HI	R	2	O/P wattage read value (High) (format: value, F=0.1)
0x010F	READ_OP_WATT_LO	R	2	O/P wattage read value (Low) (format: value, F=0.1)
0x0114	READ_OP_VA_HI	R	2	O/P apparent power read value (High) (format: value, F=0.1)
0x0115	READ_OP_VA_LO	R	2	O/P apparent power read value (Low) (format: value, F=0.1)
0x011A	READ_VBAT	R	2	Battery voltage read value (format: value, F=0.01)
0x011B	READ_CHG_CURR	R	2	Battery current read value (format: value, F=0.01)
0x011C	BAT_CAPACITY	R	2	Battery capacity percent read value, 0~100%

Command Code	Command Name	Transaction Type	# of data Bytes	Description
0x0100	INV_OPERATION	R/W	2	Operation configuration
0x0101	INV_CONFIG	R/W	2	UPS or Energy-saving mode configuration
0x0102	Output ACV_Set		2	Output AC Voltage Setting 110/220series: 1: 100/200 2: 110/220 3: 115/230 4: 120/240 0: disable(by DIP SW)
0x0103	Output ACF_Set	R/W	2	Output AC Frequency Setting 1: 50Hz 2: 60Hz 0: disable(by DIP SW)
0x0105	READ_AC_FOUT	R	2	Output AC Frequency read value (format: value, F=0.01)
0x0108	READ_AC_VOUT	R	2	Output AC Voltage read value (format: value, F=0.1)
0x010B	READ_OP_LD_PCNT	R	2	O/P load percent read value, 0~100%
0x010E	READ_OP_WATT_HI	R	2	O/P wattage read value (High) (format: value, F=0.1)
0x010F	READ_OP_WATT_LO	R	2	O/P wattage read value (Low) (format: value, F=0.1)
0x0114	READ_OP_VA_HI	R	2	O/P apparent power read value (High) (format: value, F=0.1)
0x0115	READ_OP_VA_LO	R	2	O/P apparent power read value (Low) (format: value, F=0.1)
0x011A	READ_VBAT	R	2	Battery voltage read value (format: value, F=0.01)
0x011B	READ_CHG_CURR	R	2	Battery current read value (format: value, F=0.01)
0x011C	BAT_CAPACITY	R	2	Battery capacity percent read value, 0~100%

◎MFR\_ID\_B0B5(0x0080) is the first 6 codes of the manufacturer's name (ASCII); MFR\_ID\_B6B11(0x0083) is the last 6 codes of the manufacturer's name (ASCII)

EX: Manufacturer's name is MEANWELL → MFR\_ID\_B0B5 is MEANWE ;  
MFR\_ID\_B6B11 is LL

MFR_ID_B0B5					
Byte 0	Byte 1	Byte 2	Byte 3	Byte 4	Byte 5
0x4D	0x45	0x41	0x4E	0x57	0x45

MFR_ID_B6B11					
Byte 0	Byte 1	Byte 2	Byte 3	Byte 4	Byte 5
0x4C	0x4C	0x20	0x20	0x20	0x20

◎MFR\_MODEL\_B0B5(0x0082) is the first 6 codes of the manufacturer's model name(ASCII); MFR\_MODEL\_B6B11(0x0083) is the last 6 codes of the manufacturer's model name (ASCII)

EX: Model name is NTN-5K-224 → MFR\_MODEL\_B0B5 is NTN-5K;  
MFR\_MODEL\_B6B11 is -224

MFR_MODEL_B0B5					
Byte 0	Byte 1	Byte 2	Byte 3	Byte 4	Byte 5
0x4E	0x54	0x4E	0x2D	0x35	0x4B

MFR_MODEL_B6B11					
Byte 6	Byte 7	Byte 8	Byte 9	Byte 10	Byte 11
0x2D	0x32	0x32	0x34	0x20	0x20

◎MFR\_REVISION\_B0B5 (0x0084) is the firmware revision. A range of hexadecimal 0x00(R00.0)~0xFE (R25.4) represents the firmware version of an MCU; 0xFF represents no MCU existed.

EX: The inverter has three MCUs, the firmware version of the MCU number 1 is version R01.3 (0x0D), the MCU number 2 is version R01.2 (0x0C) and the MCU number 3 is version R01.1 (0x0B).

Byte 0	Byte 1	Byte 2	Byte 3	Byte 4	Byte 5
0x0D	0x0C	0x0B	0xFF	0xFF	0xFF

◎MFR\_DATE\_B0B5 (0x0086) is manufacture date (ASCII)

EX: MFR\_DATE\_B0B5 is 180101, meaning 2018/01/01

Byte 0	Byte 1	Byte 2	Byte 3	Byte 4	Byte 5
0x31	0x38	0x30	0x31	0x30	0x31

◎MFR\_SERIAL\_B0B5 (0x0087) and MFR\_SERIAL\_B6B11 (0x0088) are defined as manufacture date and manufacture serial number (ASCII)

EX: The first unit manufactured on 2018/01/01 → MFR\_SERIAL\_B0B5: 180101 ; MFR\_SERIAL\_B6B11: 000001

MFR_SERIAL_B0B5					
Byte 0	Byte 1	Byte 2	Byte 3	Byte 4	Byte 5
0x31	0x38	0x30	0x31	0x30	0x31

MFR_SERIAL_B6B11					
Byte 6	Byte 7	Byte 8	Byte 9	Byte 10	Byte 11
0x30	0x30	0x30	0x30	0x30	0x31



©CURVE\_CONFIG(0x00B4) :

	Bit7	Bit6	Bit5	Bit4	Bit3	Bit2	Bit1	Bit0
High byte	-	-	-	-	-	FVTOE	CVTOE	CCTOE
Low byte	-	STGS	-	-	TCS		CUVS	

Low byte :

Bit 0:1 CUVS: Charge Curve Selection

00 = Customized charge Curve (default)

01 = Gel Battery

10 = Flooded Battery

11 = AGM Battery

Bit 2:3 TCS: Temperature Compensation Setting

00 = disable

01 = -3 mV/°C/cell (default)

10 = -4 mV/°C/cell

11 = -5 mV/°C/cell

Bit 6:STGS: 2/3 Stage Charge Setting

0 = 3 stage charge (default, CURVE\_CV and CURVE\_FV)

1 = 2 stage charge (only CURVE\_CV)

High byte:

Bit 0 CCTOE: Constant Current Stage Timeout Indication Enable

0 = disable (default)

1 = enabled

Bit 1 CVTOE: Constant Voltage Stage Timeout Indication Enable

0 = disable (default)

1 = enabled

Bit 2 FVTOE: Float Voltage Stage Timeout Indication Enable

0 = disable (default)

1 = enabled

Note: Unsupported settings displays with "0"

©CHG\_STATUS(0x00B8) :

	Bit7	Bit6	Bit5	Bit4	Bit3	Bit2	Bit1	Bit0
High byte	FVTOF	CVTOF	CCTOF	-	-	NTCER	-	-
Low byte	-	-	-	-	FVM	CVM	CCM	FULLM

Low byte:

Bit 0 FULLM: Fully Charged Mode Status

0 = NOT fully charged

1 = fully charged

Bit 1 CCM: Constant Current Mode Status

0 = the charger NOT in constant current mode

1 = the charger in constant current mode

Bit 2 CVM: Constant Voltage Mode Status

0 = the charger NOT in constant voltage mode

1 = the charger in constant voltage mode

Bit 3 FVM: Float Mode Status

0 = the charger NOT in float mode

1 = the charger in float mode

High byte:

Bit 2 NTCER: Temperature Compensation Status

0 = NO short-circuit in the circuitry of temperature compensation

1 = the circuitry of temperature compensation has short-circuited

Bit 5 CCTOF: Time Out Flag of Constant Current Mode

0 = NO time out in constant current mode

1 = constant current mode timed out

Bit 6 CVTOF: Time Out Flag of Constant Voltage Mode

0 = NO time out in constant voltage mode

1 = constant voltage mode timed out

Bit 7 FTTOF: Time Out Flag of Float Mode

0 = NO time out in float mode

1 = float mode timed out

Note: Unsupported settings displays with "0"

©SCALING\_FACTOR(0x00C0) :

Byte5	Bit7	Bit6	Bit5	Bit4	Bit3	Bit2	Bit1	Bit0
Definition	Reserved				Reserved			
Supported?	NO				NO			
Byte4	Bit7	Bit6	Bit5	Bit4	Bit3	Bit2	Bit1	Bit0
Definition	Reserved				Frequency Factor			
Supported?	NO				YES			
Byte3	Bit7	Bit6	Bit5	Bit4	Bit3	Bit2	Bit1	Bit0
Definition	Watt Factor				IIN Factor / IAC Factor			
Supported?	YES				YES			
Byte2	Bit7	Bit6	Bit5	Bit4	Bit3	Bit2	Bit1	Bit0
Definition	CURVE_TIMEOUT Factor				TEMPERATURE_1 Factor			
Supported?	YES				YES			
Byte1	Bit7	Bit6	Bit5	Bit4	Bit3	Bit2	Bit1	Bit0
Definition	FAN_SPEED Factor				VIN Factor / VAC Factor			
Supported?	YES				YES			
Byte0	Bit7	Bit6	Bit5	Bit4	Bit3	Bit2	Bit1	Bit0
Definition	IOUT Factor / IDC Factor				VOUT Factor / VDC Factor			
Supported?	YES				YES			

Bit 0:3 VOUT Factor/VDC Factor : The factor of output voltage/DC voltage

0x0=Output voltage relevant commands not supported

0x1~0x3=Not in use, reserved (default is 0)

0x4=0.001

0x5=0.01

0x6=0.1

0x7=1.0

0x8=10

0x9=100

0xA~0xF= Reserved

Bit 4:7 IOUT Factor/IDC Factor : The Factor of output current/ DC current

0x0=Output current relevant commands not supported

0x1~0x3=Not in use, reserved (default is 0)

0x4=0.001

0x5=0.01

0x6=0.1

0x7=1.0

0x8=10

0x9=100

0xA~0xF= Reserved

byte1:

Bit 0:3 VIN Factor/VAC Factor : The Factor of input voltage/ AC voltage Factor

0x0=AC input relevant commands not supported

0x1~0x3=Not in use, reserved (default is 0)

0x4=0.001

0x5=0.01

0x6=0.1

0x7=1.0

0x8=10

0x9=100

0xA~0xF= Reserved

Bit 4:7 FAN\_SPEED Factor : The Factor of fan speed

0x0=Fan speed relevant commands not supported

0x1~0x3=Not in use, reserved (default is 0)

0x4=0.001

0x5=0.01

0x6=0.1

0x7=1.0

0x8=10

0x9=100

0xA~0xF= Reserved

byte2:  
Bit 0:3 TEMPERATURE\_1 Factor : The Factor of internal ambient temperature  
0x0=internal ambient temperature relevant commands not supported  
0x1~0x3=Not in use, reserved (default is 0)  
0x4=0.001  
0x5=0.01  
0x6=0.1  
0x7=1.0  
0x8=10  
0x9=100  
0xA~0xF= Reserved

Bit 4:7 CURVE\_TIMEOUT Factor : The Factor of CC/CV/Float timeout  
0x0=CURVE\_TIMEOUT relevant commands not supported  
0x1~0x3=Not in use, reserved (default is 0)  
0x4=0.001  
0x5=0.01  
0x6=0.1  
0x7=1.0  
0x8=10  
0x9=100  
0xA~0xF= Reserved

byte3:  
Bit 0:3 IIN Factor/IAC Factor : The Factor of input current/AC current  
0x0=AC input current relevant commands not supported  
0x1~0x3=Not in use, reserved (default is 0)  
0x4=0.001  
0x5=0.01  
0x6=0.1  
0x7=1.0  
0x8=10  
0x9=100  
0xA~0xF= Reserved

Bit 4:7 Watt Factor : The Factor of output AC wattage (Power/Reactive/VA)  
0x0=AC wattage relevant commands not supported  
0x1~0x3=Not in use, reserved (default is 0)  
0x4=0.001  
0x5=0.01  
0x6=0.1  
0x7=1.0  
0x8=10  
0x9=100  
0xA~0xF= Reserved

byte4:  
Bit 0:3 Frequency Factor : The Factor of Frequency  
0x0=Frequency relevant commands not supported  
0x1~0x3=Not in use, reserved (default is 0)  
0x4=0.001  
0x5=0.01  
0x6=0.1  
0x7=1.0  
0x8=10  
0x9=100  
0xA~0xF= Reserved

◎SYSTEM\_CONFIG (0x00C2) :

	Bit7	Bit6	Bit5	Bit4	Bit3	Bit2	Bit1	Bit0
High byte	-	-	-	-	-	EEP_OFF	EEP_CONFIG	
Low byte	-	-	-	-	-	-	-	-

High Byte:

Bit 0:1 EEP\_CONFIG : EEPROM Configuration

00: Immediate. Changes to parameters are written to EEPROM immediately (factory default)

01: 1 minute delay. Write changes to EEPROM if all parameters remain unchanged for 1 minute

10: 10 minute delay. Write changes to EEPROM if all parameters remain unchanged for 10 minutes

11: Reserved

Bit 2 EEP\_OFF : EEPROM storage function ON/OFF

0: Enable. Parameters to be saved into EEPROM (factory default)

1: Disable. Parameters NOT to be saved into EEPROM

◎INV\_OPERATION(0x0100) :

	Bit7	Bit6	Bit5	Bit4	Bit3	Bit2	Bit1	Bit0
High byte	-	-	-	-	-	-	-	-
Low byte	-	-	-	-	-	CHG_EN	OP_EN	OP_CTRL

Low byte:

Bit 0:OP\_CTRL : AC output control

0= Turn OFF AC output

1= Turn ON AC output (Default)

Bit 1:OP\_EN: Enablement of AC output control

0= The control of AC output by the 'OP\_CTRL' bit is disabled (Default)

1= The control of AC output by the 'OP\_CTRL' bit is enabled

Bit 2:CHG\_EN : AC charger control

0= Turn OFF the AC charger when in AC bypass mode

1= Turn ON the AC charger when in AC bypass mode(Default)

Note: Unsupported settings displays with "0"

◎INV\_CONFIG(0x0101) :

	Bit7	Bit6	Bit5	Bit4	Bit3	Bit2	Bit1	Bit0
High byte	-	-	-	-	-	-	-	-
Low byte	-	-	-	-	-	-	INV_PRI0	

Low byte:

Bit 0:1 INV\_PRI0: Operation mode selection

b00 = UPS Mode (Default)

b01 = Energy-saving Mode

b10 = Reserved

b11 = Reserved

Note: Unsupported settings displays with "0"

◎INV\_STATUS(0x011D) :

	Bit7	Bit6	Bit5	Bit4	Bit3	Bit2	Bit1	Bit0
High byte	-	-	-	-	-	-	INV_PHASE	
Low byte	-	Bat_Low_ALM	SAVING	SOLAR_EN	CHG_ON	UTI_OK	BYP	INV

Low byte:

Bit 0:INV: Inverter mode

0 = The AC output is NOT provided from the inverter

1 = The AC output is provided from the inverter

Bit 1:BYP: Bypass mode

0 = The AC output is NOT provided from the external AC source (Utility)

1 = The AC output is provided from the external AC source (Utility)

Bit 2:UTI\_OK: Utility power exist

0 = Utility power failure

1 = Utility power normal

Bit 3:CHG\_ON: Charger status

0 = Charger OFF

1 = Charger ON

Bit 4:SOLAR\_ON: Solar charger control ON

0 = Enable signal for the external solar charger

1 = Disable signal for the external solar charger

Bit 5:SAVING: Saving Mode  
 0 = The inverter is NOT in Saving Mode  
 1 = The inverter is in Saving Mode

Bit 6: Bat\_Low\_ALM: Battery low alarm  
 0 = Battery low alarm is NOT triggered  
 1 = Battery low alarm is triggered

High byte:

Bit 0:1 INV\_PHASE: Inverter output phase setting  
 b00 = 0°(Default)  
 b10 = 120° (For Three-phase 4-wire configuration only)  
 b11 = -120° (For Three-phase 4-wire configuration only)

Unsupported settings displays with "0"

⊙INV\_FAULT(0x011E) :

	Bit7	Bit6	Bit5	Bit4	Bit3	Bit2	Bit1	Bit0
High byte	Reserved	Reserved	Reserved	INV_Fault	Bat_OVP	Bat_UVP	FAN_FAIL	SHDN
Low byte	EEP_Err	SCP	INV_OVP	INV_UVP	OTP	OLP_150	OLP_115	OLP_100

Low byte:

Bit 0:OLP\_100 : OLP 100 ~ 115 %  
 0 = No  
 1 = Yes

Bit 1:OLP\_115 : OLP 115 ~ 150 %  
 0 = No  
 1 = Yes

Bit 2:OLP\_150 : OLP 150% ~  
 0 = No  
 1 = Yes

Bit 3:OTP : OTP  
 0 = No  
 1 = Yes

Bit 4: INV\_UVP: Inverter UVP  
 0 = No  
 1 = Yes

Bit 5: INV\_OVP: Inverter OVP  
 0 = No  
 1 = Yes

Bit 6: SCP: Short circuit protection  
 0 = No  
 1 = Yes

Bit 7: EEP\_Err: EEPROM error code  
 0 = No  
 1 = Yes

High byte:

Bit 0: SHDN: System Shutdown  
 0 = No  
 1 = Yes

Bit 1: FAN\_FAIL: Fan lock  
 0 = No  
 1 = Yes

Bit 2: Bat\_UVP: Battery under-voltage shutdown  
 0 = No  
 1 = Yes

Bit 3: Bat\_OVP: Battery over-voltage shutdown  
 0 = No  
 1 = Yes

Bit 4: INV\_Fault: Inverter Fault  
 0 = No  
 1 = Yes

### 6.2.3 CAN Bus Communication Examples

The following provides examples of command sending and data reading for the CAN Bus protocol.

#### 6.2.3.1 Sending Command

The master adjusts CURVE\_CV of the unit with address "0" to 50V.

CAN ID	DLC(data length)	Command code	Data
0x000C0500	0x4	0xB100	0x8813

Command code: 0x00B1 (CURVE\_CV) → 0xB1(Lo) + 0x00(Hi)

Data: 50V → 5000 → 0x1388 → 0x88(Lo) + 0x13(Hi)

NOTE: Conversion factor for CURVE\_CC is  $0.01 \cdot$  so  $\frac{50V}{0.01} = 5000$

#### 6.2.3.2 Reading Data or Status

The master reads operation mode (INV\_CONFIG or 0x0101) from the unit with address "01".

CAN ID	DLC(data length)	Command code
0x000C0501	0x2	0x0101

The unit with address "01" returns data below:

CAN ID	DLC(data length)	Command code	Data
0x000C0401	0x4	0x0101	0x0000

Data: 0x0000, meaning that the unit with address "01" is operating in UPS mode.

#### 6.2.3.3 Settings of Output ACV\_Set (0x0102) and Output ACF\_Set (0x0103)

To secure settings of the AC output voltage and frequency, a different writing method is required for Output ACV\_Set(0x0102) and Output ACF\_Set(0x0103) commands, that is these commands must first be unlocked by SETTING\_UBLOCK(0x00CF) before any changes can be made.

Unlock password

- SETTING\_UBLOCK(0x00CF)

CAN ID	DLC(data length)	Command code	Data
0x000C0500	0x4	0xCF00	0x574D

Set AC output voltage

- Output ACV\_Set(0x0102)

CAN ID	DLC(data length)	Command code	Data
0x000C0500	0x4	0x0201	0x0100

NOTE: After completing the settings, please reboot the inverter to apply the new changes

#### 6.2.3.4 Remote-on/off via Communication

If ON/OFF control of the AC output via communication is required, first set Bit 1 (OP\_EN) of INV\_OPERATION(0x0100) to "1". Then, Bit 0 (OP\_CTRL) can be utilized to manage the state of the inverter's AC output. Below is an example of how to utilize the protocol to turn off the AC output.

CAN ID	DLC(data length)	Command code	Data
0x000C05XX	0x04	0x0001	0x0200

#### 6.2.4 Practical Operation

The following steps will describe how to configure the NTN-5K-148 or 248 to Energy-saving Mode and adjust its charge curve for 2-stage charging, with a constant current (CC) of 50A and a constant voltage (CV) of 56V.

- Ⓞ Set the address of the inverter to "0".

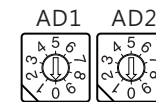

- Ⓞ Connect the CANH/CANL pins of the master to the corresponding CANH(PIN2)/CANL(PIN3) pins of the COMM connector on the inverter. It is recommended to establish a common ground for the communication system to increase its communication reliability by using GND-AUX (PIN1) of COMM.
- Ⓞ Set baud rate: 250kbps, type: extended
- Ⓞ Adding a 120Ω termination resistor to both the controller and inverter's end can increase communication stability
- Ⓞ If the unit is a terminal, it is recommended to connect a termination resistor, that is short circuit PIN1 and PIN 3 of CRL.

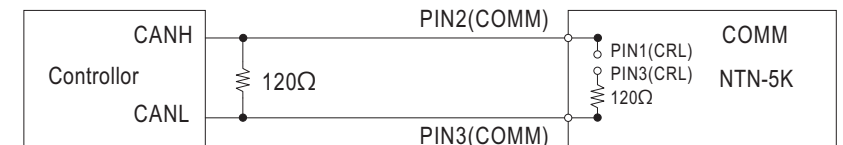

©Configure communication settings after power on. First, set the NTN-5K to 2-stage charging.

CAN ID	DLC(data length)	Command code	Data
0x000C0500	0x04	0xB400	0x4000

Command cod: 0x00B4 (CURVE\_CONFIG)

Data: 0x40(Lo) + 0x00 (Hi) • Please refer to definition of CURVE\_CONFIG for detailed information

©Set constant current to 50A

CAN ID	DLC(data length)	Command code	Data
0x000C0500	0x4	0xB000	0x8813

Command cod: 0x00B0 (CURVE\_CC)

Data: 50A → 5000 → 0x1388 → 0x88(Lo) + 0x13(Hi)

NOTE: Conversion factor for CURVE\_CC is 0.01 • so  $\frac{50A}{F0.01} = 5000$

©Set constant voltage to 56V

CAN ID	DLC(data length)	Command code	Data
0x000C0500	0x4	0xB100	0xE015

Command cod: 0x00B1 (CURVE\_CV)

Data: 56V → 5600 → 0x15E0 → 0xE0(Lo) + 0x15(Hi)

NOTE: Conversion factor for CURVE\_CC is 0.01 • so  $\frac{56V}{F0.01} = 5600$

©Set operation mode to Energy-saving Mode

CAN ID	DLC(data length)	Command code	Data
0x000C0500	0x4	0x0101	0x0100

Command cod: 0x0101 (INV\_CONFIG)

Data: 0x01(Lo) + 0x00(Hi) • Please refer to definition of INV\_CONFIG for detailed information

©Finally, check whether RC\_1(PIN3) and +5-AUX 2(PIN1) pins of the RAP1 or PAR 2 connector are short-circuited if there is no AC output voltage

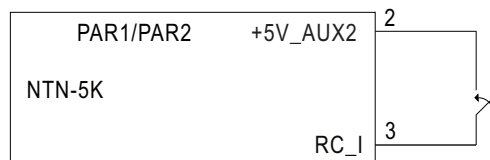

## 6.3 Value Range and Tolerance

(1)Display parameters

Command	Model	Display value range	Tolerance	
0x0050	READ_VIN	124/148	0~132Vac	±1.1Vac
		224/248/2380	0~264Vac	±2.3Vac
0x0053	READ_IIN	124/148	0~50A	±2A
		224/248/2380	0~25A	±1A
0x0056	READ_FREQ	ALL	0~70Hz	±1Hz
0x0062	READ_TEMPERATURE_1	ALL	-40~110°C	±5°C
0x0070	READ_FAN_SPEED_1	ALL	0~13000RPM	±1000RPM
0x0071	READ_FAN_SPEED_2	ALL	0~13000RPM	±1000RPM
0x0105	READ_AC_FOUT	ALL	0~70Hz	±1Hz
0x0108	READ_AC_VOUT	124/148	0~132Vac	±1.1Vac
		224/248/2380	0~264Vac	±2.3Vac
0x010B	READ_OP_LD_PCNT	ALL	0~200%	±2%
MOD: 0x010C CAN: 0x010E	READ_OP_WATT_HI	ALL	0~10000W	±100W
MOD: 0x010D CAN: 0x010F	READ_OP_WATT_LO	ALL		±100W
MOD: 0x0112 CAN: 0x0114	READ_OP_VA_HI	ALL	0~10000VA	±100VA
MOD: 0x0113 CAN: 0x0115	READ_OP_VA_LO	ALL		±100VA
0x011A	READ_VBAT	124/224	0~35V	±0.24V
		148/248	0~70V	±0.48V
		2380	0~450V	±3.8V
0x011B	READ_CHG_CURR	124	-240~120A	±2.4A
		224	-280~135A	±2.7A
		148	-120~60A	±1.2A
		248	-140~70A	±1.4A
		2380	-15~11.3A	±0.23A

Command		Model	Display value range	Tolerance
0x011C	BAT_CAPACITY	ALL	25/50/75/100%	±25%
0x011F	READ_BP_WATT_HI	ALL	0~10000W	±300W
0x0120	READ_BP_WATT_LO	ALL		±300W
0x0125	READ_BP_VA_HI	ALL	0~10000VA	±300VA
0x0126	READ_BP_VA_LO	ALL		±300VA
0x012B	READ_AC_IOUT	124/148	0~100A	±1A
		224/248/2380	0~50A	±0.5A

## (2)Control parameters

Command		Model	Display value range	Tolerance	Default
0x00B0	CURVE_CC	124	24~120A	±2.4A	120A
		224	27~135A	±2.7A	135A
		148	12~60A	±1.2A	60A
		248	14~70A	±1.4A	70A
		2380	2.26~11.3A	±0.23A	11.3A
0x00B1	CURVE_CV	124/224	20~30V	±0.24V	28.8V
		148/248	40~60V	±0.48V	57.6V
		2380	290~400V	±3.8V	400V
0x00B2	CURVE_FV	124/224	20V~CURVE_CV	±0.24V	27.6V
		148/248	40V~CURVE_CV	±0.48V	55.2V
		2380	290~ CURVE_CV	±3.8V	385V
0x00B3	CURVE_TC	124	2.4~36A	±2.4A	12A
		224	2.7~40.5A	±1.35A	13.5A
		148	1.2~18A	±1.2A	6A
		248	1.4~21A	±0.7A	7A
		2380	0.226~3.39A	±0.113A	1.13A
0x00B4	CURVE_CONFIG	ALL	N/A	N/A	0004h
0x00B5	CURVE_CC_TIMEOUT	ALL	60 ~ 64800 minute	±5 minute	600 minute
0x00B6	CURVE_CV_TIMEOUT				
0x00B7	CURVE_FV_TIMEOUT				

Command		Model	Display value range	Tolerance	Default
0x00B9	BAT_ALM_VOLT	124/224	18.8V~25V	±0.24V	22V
		148/248	37.6V~50V	±0.48V	44V
		2380	275V~335V	±3.8V	300V
0x00BA	BAT_SHDN_VOLT	124/224	18.4V~24V	±0.24V	19V
		148/248	36.8V~48V	±0.48V	38V
		2380	270V~320V	±3.8V	280V
0x00BB	BAT_RCHG_VOLT	124/224	18.4V~CURVE_FV	±0.24V	18.4V
		148/248	36.8V~CURVE_FV	±0.48V	36.8V
		2380	270V~ CURVE_FV	±3.8V	270V
MOD: 0x00C4 CAN: 0x00C2	SYSTEM_CONFIG	ALL	N/A	N/A	0000h
0x0100	INV_OPERATION	ALL	N/A	N/A	0005h
0x0101	INV_CONFIG	ALL	N/A	N/A	0000h
0x0102	Output ACV_Set	ALL	N/A	N/A	0000h
0x0103	Output ACF_Set	ALL	N/A	N/A	0000h

Note:

i.READ\_CHG\_CURR will display ZERO amp when output current is less than values in the table below.

Model	Minimum readable	Model	Minimum readable
124	2.03A±2.4A	248	1.05A±1.4A
224	2.03A±2.7A	2380	0.17A±0.23A
148	1.05A±1.2A		

ii.If the AC output is set to OFF by the INV\_OPERATION (0x0100) command via the communication protocol, it will revert to ON when the inverter is recycled.

iii.Due to the limited write cycles of the EEPROM, it is advisable to consider using the SYSTEM\_CONFIG (0x00C4) command to select an appropriate EEPROM writing logic, especially if parameter settings are frequently altered.

iiii.Writing parameters to Output ACV\_Set (0x0102) and Output ACF\_Set (00103) commands require a reboot to take effect.



## 7. Protections and Troubleshooting

### 7.1 Protections

#### AC Output Protection:

- AC Output Overload Protection:  
When the inverter is overloaded, it can still supply AC power for a short period of time. If the loads do not return to the normal range, the OLP will be triggered, automatically turning off the inverter. Once the overload condition is resolved, it is necessary to re-power on the inverter to resume operation.

#### AC Output Short Circuit Protection :

- When a short circuit occurs or the load increases significantly, the inverter will turn off for protection. Once the faulty condition is resolved, it is necessary to re-power on the inverter to resume operation.

#### DC Input Protection:

- DC Polarity Protection:  
When the DC polarity is connected reversely, the inverter will not be damaged but with no function. Once the faulty condition is resolved, re-power on the inverter to resume normal operation.
- Low DC Input Protection :  
When the DC input falls below the operating range, the inverter will automatically turn off for protection. After the fault condition is removed, inverter will restart automatically.
- Over Voltage of DC Input :  
When the voltage of DC input over the operating range, the inverter will turn off for protection. After the fault condition is removed, inverter will restart automatically. If the inverter cannot operate normally afterwards, it represents that the inverter is damaged. Please return the unit to MEAN WELL's distributor for further service.

#### Inverter Protection:

##### Over Temperature Protection (OTP):

When the temperature inside the inverter reaches a certain level, the inverter will automatically turn off for protection. After the temperature drops back to the operating range, the inverter will restart automatically.

### 7.2 Troubleshooting

Once a failure condition occurs, the LEDs on the AC panel will display a specific code to indicate its faulty condition. The fault conditions can be classified into 4 categories: AC output protection, DC input protection, over-temperature protection, or others. Please refer to the following table for troubleshooting. If the fault condition cannot be resolved, please contact MEAN WELL's distributor for further assistance.

fault signal	Possible cause	Suggestions for Fault correction
Status ● DC Input ○ Load ☀	Over load protection	Check if the load requires high startup current, such as inductive or capacitance loads. After the fault condition is removed, re-power the inverter for operation.
	Short circuit protection	Check if the load requirement exceeds the rated value or if the circuit is shorted.
Status ● DC Input ☀ Load ○	Aged battery or malfunction	Replace with a new battery
	Wrong battery capacitance	Re-check if the parameter of battery suits inverter's operating parameter
Status ● DC Input ☀ Load ☀	Over temperature protection	Remove subject away from venthole if any. If it's due to high ambient, please lower the temperature or load to proceed. After the temperature drops back to the operating range, the inverter will restart automatically.
Status ☀ DC Input ○ Load ○	Other fault condition that's not defined	Contact MEAN WELL's distributor

Note: ● Light  
 ☀ Flash  
 ○ Light off

## 8. Warranty

This product provides 5 years warranty under normal usage. Do not replace parts or any form of modification to the product in order to keep the warranty effectively.

※ MEAN WELL posses the right to adjust the content of this manual. Please refer to the latest version of our manual on our website. <https://www.meanwell.com>



## 9. Environmental declaration information

[https://www.meanwell.com//Upload/PDF/RoHS\\_PFOS.pdf](https://www.meanwell.com//Upload/PDF/RoHS_PFOS.pdf)  
[https://www.meanwell.com//Upload/PDF/REACH\\_SVHC.pdf](https://www.meanwell.com//Upload/PDF/REACH_SVHC.pdf)  
[https://www.meanwell.com//Upload/PDF/Declaration\\_RoHS-E.pdf](https://www.meanwell.com//Upload/PDF/Declaration_RoHS-E.pdf)

明緯企業股份有限公司

MEAN WELL ENTERPRISES CO., LTD.

248 新北市五股區五權三路28號

No.28, Wuquan 3rd Rd., Wugu Dist., New Taipei City 248, Taiwan

Tel: 886-2-2299-6100 Fax: 886-2-2299-6200

<http://www.meanwell.com> E-mail: [info@meanwell.com](mailto:info@meanwell.com)